

OPERATOR'S SAFETY AND SERVICE MANUAL



F90-2/4

This manual covers the following serial numbers
and higher for each model listed:

F90-2/4 1503000



RIDE ON TROWELS

MBW, Inc.
250 Hartford Rd • PO Box 440
Slinger, WI 53086-0440
Phone: (262) 644-5234
Fax: (262) 644-5169
Email: mbw@mbw.com
Website: www.mbw.com

MBW Europe Ltd.
Units 2 & 3 Cochrane Street
Bolton BL3 6BN, England
Phone: 01204 387784
Fax: 01204 387797



Solutions that last

M-B-W EUROPE LTD

Units 2 & 3 Cochrane Street, Bolton BL3 6BN

Tel: 01204 387784 Fax: 01204 387797

email: mbweurope@mbw.com ➤ www.mbweurope.com

Foreword

Quality assurance / machine break in

The MBW Trowel Ride-on Trowel is the product of extensive engineering development designed to give long life and unmatched performance. Once machines are fully assembled, a run-in test is performed to ensure quality standards of the highest level. A series of operational tests are conducted on concrete, incorporating a phase of operations at 1/2 to 3/4 throttle for a minimum of 20 minutes and a final run phase at full throttle for a minimum of 25 minutes.

You can help ensure that your Ride-on will perform at top levels by observing a simple routing on first use. Consider that your new Ride-on Trowel is like a new car. Just as you would break in a new car to the road or any new machine to the job, you should start gradually and build up to full use. Learn what your machine can do and how it will respond. Refer to the engine manufacturer's manual for run-in times. Full throttle and control may be used after this time period, as allowed by material. This will serve to further break in the machine on your specific application, as well as provide you with additional practice using the machine.

We thank you for the confidence you have placed in us by purchasing a MBW Trowel Ride-on Trowel and wish you many years of satisfied use.





Solutions that last

M-B-W EUROPE LTD

Units 2 & 3 Cochrane Street, Bolton BL3 6BN

Tel: 01204 387784 Fax: 01204 387797

email: mbweurope@mbw.com > www.mbweurope.com

Table of contents

Foreword	2
Safety precautions	4
Assembly instructions	5
1 Battery – Shipped dry – No acid	5
2 Steering handle assembly	5
3 Pitch control Assembly	5
4 Seat Assembly	6
5 Transporter Assembly	6
Operating Instructions	7
1 Starting procedures – warm temperatures	7
2 Starting procedures – cold temperatures	7
3 To Stop engine	7
4 Steering	8
5 Float/Trowel pitch setting	9
6 Blade synchronization (specially modified units only)	9
7 Transporter Use	10
Trowel arm adjustment fixture	11
1 Adjustment Procedure	12
2 Trowel arm adjustment screw	13
Maintenance	14
1 Preventative maintenance and routine service plan	14
2 Lubrication	15
3 Maintenance plan	16
4 Service	18
Labels	19
Specifications	20
1 Technical data sheet	20
2 Parts	21





Solutions that last

M-B-W EUROPE LTD

Units 2 & 3 Cochrane Street, Bolton BL3 6BN

Tel: 01204 387784 Fax: 01204 387797

email: mbweurope@mbw.com ➤ www.mbweurope.com

Safety Precautions

- ❖ Always keep unauthorized, inexperienced, untrained people away from this machine.
- ❖ Rotating and moving parts will cause injury if contacted. Make sure guards are in place. Keep hands and feet away from moving parts.
- ❖ Fuel the machine only when the engine is stopped, using all necessary safety precautions.
- ❖ The engine must always be stopped before attempting any repair or adjustments. Ignition key should be off.



Danger: Never operate the machine in an explosive atmosphere, near combustible materials or where ventilation does not clear exhaust fumes. Repair fuel leaks immediately.
Refer to your engine owner's manual for more safety instructions.

- ❖ Be careful not to come in contact with the muffler when the engine is hot, serious burns may result!
- ❖ Always operate the machine in a seated position to maintain machine balance.
- ❖ The transporter is designed for moving the unit around the job site only. It is not to be used for towing the Ride-On unit off-site.
- ❖ When starting the trowel, do not exceed the ¼ throttle position as recommended. A higher setting could cause the centrifugal clutch to engage, turning the trowel blades.
- ❖ Be careful with the trowel around stub pipes or other obstructions on the floor. Should the machine catch, or hit such an obstruction, serious damage may result to the machine, or operator may be thrown from the machine.
- ❖ Excess surface water may result in sudden loss of control of steering.
- ❖ Disconnect battery before attempting any electrical maintenance.
- ❖ Ensure that the electrical dead-man switch, located on the right hand steering lever is operating. Placing your right hand on the steering lever will engage the safety switch. Removing your hand from the Lever will disengage the safety switch and stop the engine. The engine will not start unless the safety switch is depressed. This safety feature must be used as designed





Solutions that last

M-B-W EUROPE LTD

Units 2 & 3 Cochrane Street, Bolton BL3 6BN

Tel: 01204 387784 Fax: 01204 387797

email: mbweurope@mbw.com > www.mbweurope.com

Assembly Instructions

1 Battery – Shipped dry – No acid

Connect and secure the battery cables before attempting starting procedures.

2 Steering handle assembly

The steering handles are shipped ready to connect. Position the handles over the handle sleeves so that the set-screws (2 per handle) are lined up with the tapped holes on the sleeves. Tighten the set-screws and test the mobility of the handles.

3 Pitch control Assembly

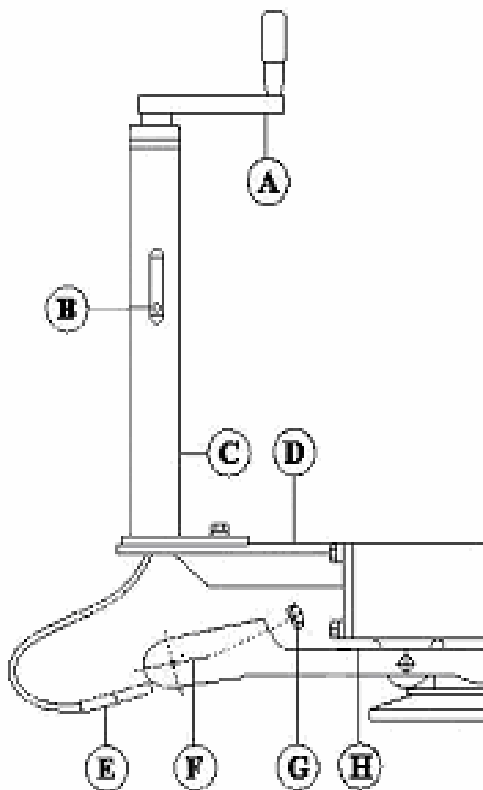

Bolt pitch control tube (C) to pitch control bracket (D) with bolts provided. Put cable end (E) through yoke arm (F) and secure with nylon insert locknut (G). For proper cable adjustment, turn crank (A) counter-clockwise to the stop position. Tighten nut (G) until all slack in the cable is removed. If more than 2 or 3 threads show through the nut, it should be turned back and the guide screw (B) moved to the next lower hole. Tension in the cable should then be readjusted. After adjusting tension, turn hand crank full clockwise (ABOUT 24 TURNS) and check for clearance between the yoke arm (F) and the gear box at point (H). There should be enough space to pass a business card through but not more than 1/8 inch.





M-B-W EUROPE LTD

Units 2 & 3 Cochrane Street, Bolton BL3 6BN

Tel: 01204 387784 Fax: 01204 387797

email: mbweurope@mbw.com ➤ www.mbweurope.com

Solutions that last

4 Seat Assembly

Remove protective wrapping from seat. The seat is now ready to secure to the frame using included washers and hex nuts. If the seat adjuster is ordered, the slider bars must be positioned between the seat and the frame using included screws to secure the seat to the sliders, and then securing the sliders to the frame as indicated above.

5 Transporter Assembly

The components of the transporter (handle, frame, wheels, and parts bag) are shipped separately, requiring some assembly. Extend the handle outside the frame. Slide the handle along the frame cross-bar to align the hole on the handle with the hole on the "U" frame. Insert the large hitch pin (part #12487) through the hole to secure the handle to the "U" frame. Position one of the wheels on the axle and secure in place by inserting pin (part #10315) into the hole on the end of the axle. Repeat procedure for the other wheel.



CAUTION: The transporter is designed to be used on the job site only. Do not use the transporter to tow the machine off-site.





Solutions that last

M-B-W EUROPE LTD

Units 2 & 3 Cochrane Street, Bolton BL3 6BN

Tel: 01204 387784 Fax: 01204 387797

email: mbweurope@mbw.com > www.mbweurope.com

Operating Instructions

1 Starting procedures – warm temperatures

- ❖ Prior to starting the trowel, check the engine and gearbox oil levels. Be sure the fuel tank is full.
Fuel is not shipped with the unit. Before attempting to start, fill the fuel tank. Check engine and gearbox oil levels. **WARRANTY IS VOID IF RUN WITHOUT OIL.** Fill tank with safety approved fuel containers. **DO NOT MIX OIL WITH FUEL.**
- ❖ Maintain left foot pressure on the dead-man safety switch. Engine will disengage and stop if safety switch is released. Do not tape, tie-down, or otherwise attempt to bypass safety device..
- ❖ Turn ignition key all the way. Allow engine to warm up before proceeding with full trowel operation.

2 Starting procedures – cold temperatures

Follow same procedure as above but allow for a longer warm up period 3-5 min. (In cold weather oil is much heavier to move. Extra time is required to heat the oil.)

3 To Stop engine

- ❖ Bring throttle to low idle, wait a few seconds.
- ❖ Remove left foot from dead-man safety switch.
- ❖ Turn off ignition key.





Solutions that last

M-B-W EUROPE LTD

Units 2 & 3 Cochrane Street, Bolton BL3 6BN

Tel: 01204 387784 Fax: 01204 387797

email: mbweurope@mbw.com > www.mbweurope.com

4 Steering

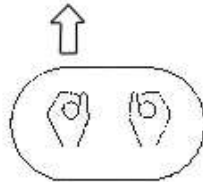

FORWARD



REVERSE

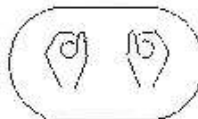

CLOCKWISE



C-CLOCKWISE



LEFT



RIGHT

Guiding the machine on the slab is quite simple but does require some familiarity before actually working with the machine. The controls respond as shown in figure 2a below. Test the machine on a finished section of the floor, with the blades in a flat position, and the engine at a low revolution to gain the necessary feel for the steering.

For straight line movement, move both handles as one in the direction you wish to travel. Move the handles in opposite directions to produce rotation on the machines axis. Left handle forward, right handle backward for clockwise rotation. Left handle backward, right handle forward, for counter-clockwise rotation. Sideways direction is achieved by sideways movement of the right handle in the required direction of travel.



WARNING: SERIOUS INJURY OR PROPERTY DAMAGE MAY RESULT DUE TO TEMPORARY LOSS OF CONTROL IF OPERATED WITH EXCESS LIQUID ON THE CONCRETE SURFACE.





Solutions that last

M-B-W EUROPE LTD

Units 2 & 3 Cochrane Street, Bolton BL3 6BN

Tel: 01204 387784 Fax: 01204 387797

email: mbweurope@mbw.com > www.mbweurope.com

5 Float/Trowel pitch setting

Once you are familiar with the steering functions on a flat floor, you are ready to combine the steering with float/trowel pitch settings to produce the finish you require. The pitch adjustment feature of the **MBW** Trowel RIDE-ON TROWEL permits quick and accurate pitch changes of the finishing/float blades, without having to stop the machine. Turning the adjustment crank-handle at the end of the pitch control tubes enables you to change the pitch whenever necessary to allow for varying conditions over the slab surface.

Each spider plate is adjusted independently. The pitch setting will affect the steering of your unit. Experiment with the settings as you test drive so you will know what to expect.



CAUTION: Do not let the machine stand in one spot on the soft cement; This may place unnecessary strain on the clutch to break it free of the cement. If the unit has been sitting for any length of time, break it free from the concrete before attempting operation.



CAUTION: When finishing concrete above grade, erect a situation barrier along the edge of the slab as a protective measure. The barrier should be such that it will stop the trowel from riding over the edge of the slab in case of loss of control.

6 Blade synchronization (specially modified units only)

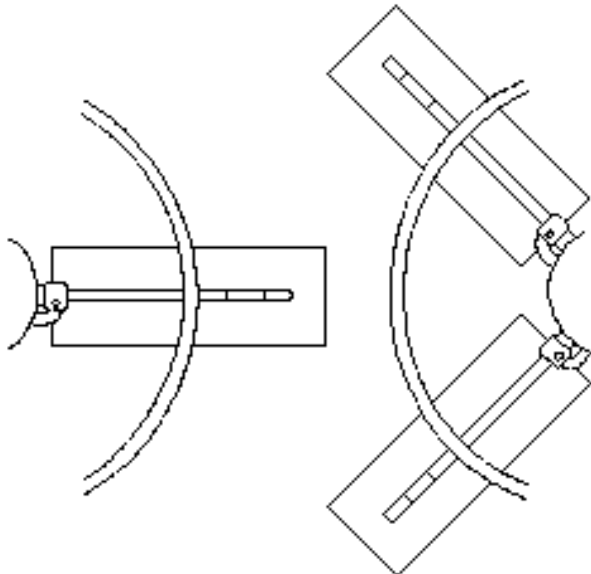

To avoid blades hitting, make sure spider plates are positioned as shown with respect to each other after performing any maintenance.





M-B-W EUROPE LTD

Units 2 & 3 Cochrane Street, Bolton BL3 6BN

Tel: 01204 387784 Fax: 01204 387797

email: mbweurope@mbw.com ➤ www.mbweurope.com

Solutions that last

7 Transporter Use



The transporter is designed to be used on the job site only. Do not use it to tow the machine offsite.

The transporter has pick-up brackets located on the inside of the wheels which should be positioned under the pick-up points on the frame. Before connection, the handle will be pointing upwards at approximately a 45 degree angle. Pull the handle down, engaging the transporter and secure the bracket and transporter to the frame by locking the handle bracket in the frame lock by means of the hitch pin. Using the handle as a lever, the ride-on may now be moved. To disconnect the transporter, follow the above steps in reverse.

www.mbweurope.com





Solutions that last

M-B-W EUROPE LTD

Units 2 & 3 Cochrane Street, Bolton BL3 6BN

Tel: 01204 387784 Fax: 01204 387797

email: mbweurope@mbw.com > www.mbweurope.com

Trowel arm adjustment fixture

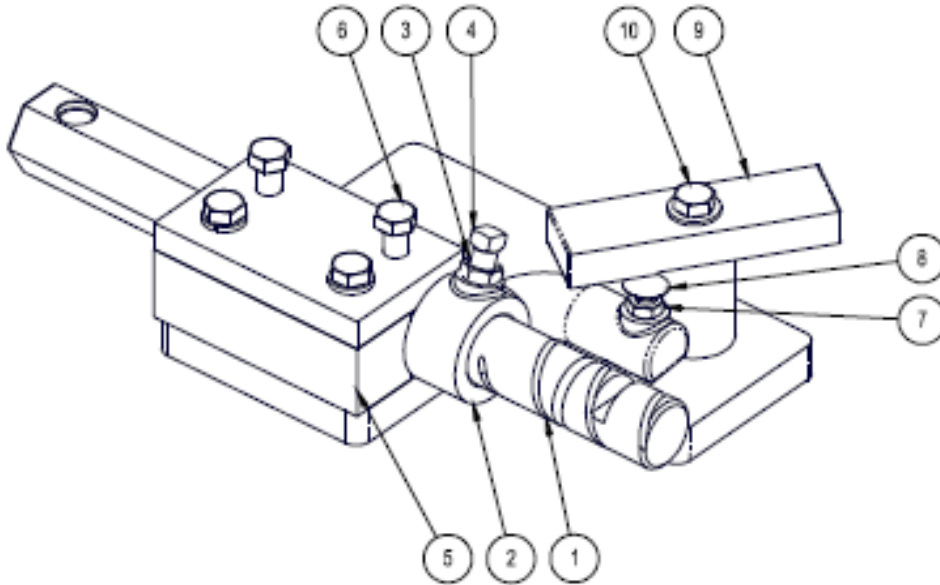

- 1) 10411 – Trowel arm
- 2) 10817 – Lift lever
- 3) 10808 – Jam nut
- 4) 10809 – Set screw
- 5) 10824 – Block top

- 6) 10507 – Bolt
- 7) 10816 – Jam nut
- 8) 10815 – Carriage bolt
- 9) 10832 – Adjustment bar
- 10) 10507 – Bolt

The trowel arm adjustment fixture (20801) is reversible. By rotating the arm clamping fixture and the ring bolt, both left hand and right hand trowel arms may be adjusted. Before attempting adjustment, determine whether the trowel arm is right handed or left handed. When adjusting left hand trowel arms use the side of the fixture marked “L”. When adjusting right hand trowels arms use the opposite side. The adjustment bar will be set on “36” for the FJ€trowel arm.





M-B-W EUROPE LTD

Units 2 & 3 Cochrane Street, Bolton BL3 6BN

Tel: 01204 387784 Fax: 01204 387797

email: mbweurope@mbw.com ➤ www.mbweurope.com

Solutions that last

1 Adjustment Procedure

- ❖ Remove all trowel arm assemblies (1 & 2 arm and attached lift lever) from suspected maladjusted spider plate.
- ❖ Remove lift lever (2) from trowel arm (1) by first loosening jam nut (3) then square head screw (4). If upon inspection (method left to discretion of serviceman) any trowel arm (1) is found to be in a bent condition, it must either be brought back to its original straight condition (method left to the serviceman's discretion) or replaced with new part.
- ❖ Replace lift levers (2) on new or straightened arms (1) by reversing procedure described above.



NOTE: IT IS IMPORTANT THAT WHEN TIGHTENING SQUARE HEAD NUT (4), IT SEATS ITSELF SECURELY INTO DIMPLE MACHINED IN ARM.

- ❖ Place trowel arm assembly (1 and 2) in fixture (5) with lift lever (2) butting up against fixture. Secure in place with bolts (6).
- ❖ Loosen locknut (7) and screw carriage bold (8) down to full depth allowable. This will provide for ample clearance to swing adjustment bar (9) over head of carriage bolt. Adjustment bar (9) is stamped for appropriate size of machine. Swing appropriate side directly over carriage bolt (8) and secure in place with bolt (10).
- ❖ Adjust carriage bolt (8) upwards until contact is made with adjustment bar (9); holding carriage bolt in position with one wrench, tighten locknut (7) to secure in position with second wrench.



NOTE: IT IS VITALLY IMPORTANT TO ENSURE THAT ONCE THE CARRIAGE BOLT IS ADJUSTED TO THE CORRECT HEIGHT, IT DOES NOT MOVE BEFORE, OR DURING THE TIGHTENING OF LOCKNUT.

- ❖ This same procedure is to be followed with ALL arms from spider plate assembly, and will ensure correct and exact adjustment.





M-B-W EUROPE LTD

Units 2 & 3 Cochrane Street, Bolton BL3 6BN

Tel: 01204 387784 Fax: 01204 387797

email: mbweurope@mbw.com ➤ www.mbweurope.com

Solutions that last

2 Trowel arm adjustment screw

When assembling trowel blades to trowel arms, the adjustment screw should NEVER protrude below the under-side surface to a trowel arm except when using for emergency on-site adjustment to level trowel blades. If the adjustment screw is not flush with the underside of the trowel arm, then this will cause the power trowel to bounce and vibrate especially at high speed. This will also cause the trowel blades to leave an uneven finish to the concrete due to the blades not being level to one another. Make certain that the adjusting screw is held firmly in place while tightening the bolt which secures the blade to the trowel arm.





Solutions that last

M-B-W EUROPE LTD

Units 2 & 3 Cochrane Street, Bolton BL3 6BN

Tel: 01204 387784 Fax: 01204 387797

email: mbweurope@mbw.com > www.mbweurope.com

Maintenance

1 Preventative maintenance and routine service plan

This trowel has been assembled with care and will provide years of service. Preventative maintenance and routine service are essential to the long life of your trowel. Your dealer is interested in your new machine and has the desire to help you get the most value from it. After reading through this manual thoroughly, you will find that you can do some of the regular maintenance yourself. However, when in need of parts or major service, be sure to see MBW Trowel.

❖ GENERAL

- Keep engine oil clean. Change according to engine manufacturer's specifications.
- Maintain the oil levels in the engine and gearbox assemblies. Change as required.
- Use only clean fuel in the engine.
- Check for loose nuts and bolts on the trowel and tighten as necessary.
- Check "V" belts for wear, replace if worn.
- Grease all fittings daily. See diagram.
- Clean the unit after every use to prevent hardening of sludge. Hard concrete is very difficult to remove, greatly increases weight and reduces efficient subsequent operation of unit.
- Check clutch linings regularly for wear. Linings should be changed when 3/4 worn. Do not allow metal to metal contact as this will damage the clutch drum. (New lining is 8mm.)

❖ AIR CLEANER

Maintaining a clean engine will extend engine life. Keep air filter clean at all times. Clean air filter using the recommended solvent daily. See engine manual for proper cleaning procedure. Let the filter dry before reinstalling.

❖ SPARK PLUG

Check and clean spark plugs regularly. A fouled, dirty spark plug caused hard starting and poor engine performance. Set spark plug gap to recommended clearance. Refer to engine manual.





M-B-W EUROPE LTD

Units 2 & 3 Cochrane Street, Bolton BL3 6BN

Tel: 01204 387784 Fax: 01204 387797

email: mbweurope@mbw.com > www.mbweurope.com

Solutions that last

❖ BELT CHANGE PROCEDURE

Remove belt cover from the machine to expose the drive components. To change the primary drive belt, remove clutch from engine drive shaft, by removing bolt from the clutch. This releases belt from both the clutch and driven unit.

❖ BELT TENSIONING SPECIFICATIONS



NOTE: Belts may become slightly loose after the first few hours of operation. It is important to retension the belts with the tool provided and use the table given as reference.

2 Lubrication

❖ ENGINE OIL

The long life and successful operation of any piece of machinery is dependent on frequent and thorough lubrication.

Before using the trowel, always check your engine for oil. Use proper engine oil as recommended in the engine manufacturer's manual. Fill crankcase to levels as recommended.

❖ SPIDER PLATE

There are 8 (eight) grease fittings on the spider plates, 4 (four) on each must be greased daily.

SPIDER PLATES MUST BE GREASED EVERY TIME MACHINE IS USED.

❖ GEARBOX

Check the oil level sight plugs on both gearboxes daily to ensure the oil is half way on the site glass. Top up with Agma 8 compounded gear oil only. Gearbox capacity on the F90 is 27oz./767ml.

❖ TO CHANGE GEARBOX OIL

Place a pan beneath the drain plug to catch the oil. Remove the drain plug and the filler plug from the gearbox. After the oil has drained completely, replace the drain plug and tighten. Fill the gearbox through the filler plug with 27oz./767ml. of Agma 8 compounded gear oil. Replace the filler plug and tighten.

❖ GREASE FITTINGS

There are 6 bearings in total. Grease all bearings and U-joints to ensure adequate supply of lubricant. They are located above the gearboxes (2 per gearbox) and 2 located in the drive system. The U-joints are located in the drive system as well.





M-B-W EUROPE LTD

Units 2 & 3 Cochrane Street, Bolton BL3 6BN

Tel: 01204 387784 Fax: 01204 387797

email: mbweurope@mbw.com ➤ www.mbweurope.com

Solutions that last

3 Maintenance plan

Routine Service Intervals - Continued -		Each use	After 1.5 months or 50 hrs	Each 3 months or 100 hrs	Each 6 months or 200 hrs	Each 9 months or 300 hrs	Each 12 months or 400 hrs
Drive Train:							
Bearings	Lubricate	o	o	o	o	o	o
Universal couplings	Lubricate			o	o	o	o
Belt tension / Condition	Check	o	o	o	o	o	o
Clutch / Pulley operation	Check	o	o	o	o	o	o
LH spider plate assembly	Check	o		o	o	o	o
	Lubricate	o	o	o	o	o	o
RH spider plate assembly	Check	o		o	o	o	o
	Lubricate	o	o	o	o	o	o
Gearboxes:							
LH Gearbox oil	Check Level	o	o	o	o	o	o
	Change				o		o
RH Gearbox oil	Check Level	o	o	o	o	o	o
	Change				o		o
Gearbox breathers	Check operation			o	o	o	o
Retardant Spray System:							
Water pump operation	Check	o	o	o	o	o	o
Spray nozzles	Clean	o					
Retardant Fluid	Check levels	o					

www.mbweurope.com





M-B-W EUROPE LTD

Units 2 & 3 Cochrane Street, Bolton BL3 6BN

Tel: 01204 387784 Fax: 01204 387797

email: mbweurope@mbw.com ➤ www.mbweurope.com

Solutions that last

Routine Service Intervals		Each use	After 1.5 months or 50 hrs	Each 3 months or 100 hrs	Each 6 months or 200 hrs	Each 9 months or 300 hrs	Each 12 months or 400 hrs
General Inspection:							
Operation of lights	Check		o	o	o	o	o
Battery	Clean & Check			o	o	o	o
	Recharge			o	o	o	o
	Replace						2 yrs
Guards	Check	o	o	o	o	o	o
Warning stickers	Check		o	o	o	o	o
Test run:	Check operation		o	o	o	o	o
Controls:							
Dead-man switch operation	Check	o	o	o	o	o	o
Throttle pedal operation	Check	o	o	o	o	o	o
Steering linkages	Check	o	o	o	o	o	o
	Lubricate		o	o	o	o	o
	Replace						As req'd
Pitch control levers	Check	o	o	o	o	o	o
	Lubricate		o	o	o	o	o
Joystick controls (N/A)	Check	o					
Hydraulic system (N/A)	Check levels			o	o	o	o
	Check hoses			o	o	o	o
	Replace hoses						2 yrs
Engine:							
Fuel pipes & clamps	Check		o	o	o	o	o
	Replace						2 yrs
Engine oil	Check Level	o	o	o	o	o	o
	Change		o		o		o
Engine oil filter	Replace				o		o
Oil cooler	Clean			o	o	o	o
Cooling Fins	Clean		o	o	o	o	o
Air cleaner	Check - clean	o	o	o	o	o	o
	Replace						o
Air Intake Line	Check				o		
	Replace						2 yrs
Fan Belt	Check tightness				o		o
	Replace						500 hrs
Valve clearance	Check-adjust				o		o
Fuel filter	Check & Clean			o	o	o	o
	Replace				o		o
Fuel Tank	Clean						500 hrs
Fuel Injection Nozzles	Check pressure						500 hrs
Fuel Injection Timer	Check						500 hrs
Injection Pump	Check						500 hrs
Engine wiring	Check						o





M-B-W EUROPE LTD

Units 2 & 3 Cochrane Street, Bolton BL3 6BN

Tel: 01204 387784 Fax: 01204 387797

email: mbweurope@mbw.com > www.mbweurope.com

Solutions that last

4 Service

Due to the nature and environment of use, power trowels are exposed to severe operating conditions.

Some general maintenance guidelines will extend the useful life of your trowel.

- ❖ The initial service for your power trowel should be performed after 25 hours of use, at which time your mechanic (or authorized repair shop) should complete all of the recommended checks in the schedule above.
- ❖ Regular service according to the schedule above will prolong the life of the power trowel and prevent expensive repairs.
- ❖ Keeping your power trowel clean and free from concrete residue is the single most important regular maintenance operation, over and above the checks in the service schedule above, that can be performed.
Components such as oil seals, belts, drive line parts and bearings are prone to premature wear from exposure to concrete residue. Using a spray-on release agent on your power trowel before each use will make clean-up after use easy and extend the time between replacement of most of the wearing components of the machine.
- ❖ After each use your power trowel should be cleaned to remove any concrete residue from the undercarriage and surrounding components. Use of a power washer will make clean up quick and easy, especially if a non-stick coating was applied prior to use.
- ❖ In the Service Schedule above, items that should be checked, replaced or adjusted are indicated by "o" in the appropriate column. Not all power trowel models include the same features and options and as such not all service operations may have to be performed. For ease of recording place a checkmark (✓) through the "o" when the item is complete. If an item is not required or not completed place an "x" through the "o" in the box.
- ❖ For all fuel-line powered trowels the governed speed of the engine is 2000 to 3600 rpm. See engine manufacturer's manual for exact specifications. Care should be used when making any adjustments to the power trowel not to change the governed speed. Increasing the governed speed of the engine may lead to premature failure and void the manufacturer's warranty.
- ❖ Failure to have your power trowel regularly serviced and properly maintained in accordance with the manufacturer's instructions will lead to premature failure and void the warranty.





Solutions that last

M-B-W EUROPE LTD

Units 2 & 3 Cochrane Street, Bolton BL3 6BN

Tel: 01204 387784 Fax: 01204 387797

email: mbweurope@mbw.com ➤ www.mbweurope.com

Labels

SAFETY PRECAUTIONS	
	<p>! DANGER</p> <p>EXPLOSION HAZARD Never operate the machine in an explosive atmosphere, near combustible materials or where ventilation does not clear exhaust fumes.</p>
	<p>WARNING</p> <p>BURN HAZARD Never come into contact with the engine or muffler when engine is operating or shortly after it is turned off. Serious burns may occur.</p>
	<p>! CAUTION</p> <p>ROTATING HAZARD Never place hands or feet inside safety guard rings. Serious injury will result from contact with rotating blades.</p>
	<p>! CAUTION</p> <p>MOVING PARTS Before starting the machine ensure that all guards and safety devices are in place and functioning properly.</p>
	<p>! ATTENTION</p> <p>READ OWNERS MANUAL Read and understand operator's manual before using this machine. Failure to follow operating instructions could result in serious injury or death.</p>





M-B-W EUROPE LTD

Units 2 & 3 Cochrane Street, Bolton BL3 6BN

Tel: 01204 387784 Fax: 01204 387797

email: mbweurope@mbw.com > www.mbweurope.com

Solutions that last

Specifications

1 Technical data sheet

GASOLINE ENGINE	HONDA 24 HP
DIAMETER IN CM	2 X 90
WEIGHT IN KG.	285
WORKING LENGTH IN CM	93
WORKING WIDTH IN CM	187
ROTATIONS SPIDER ARMS	MAX. 165

www.mbweurope.com





Solutions that last

M-B-W EUROPE LTD

Units 2 & 3 Cochrane Street, Bolton BL3 6BN

Tel: 01204 387784 Fax: 01204 387797

email: mbweurope@mbw.com > www.mbweurope.com

Parts

1. Framework

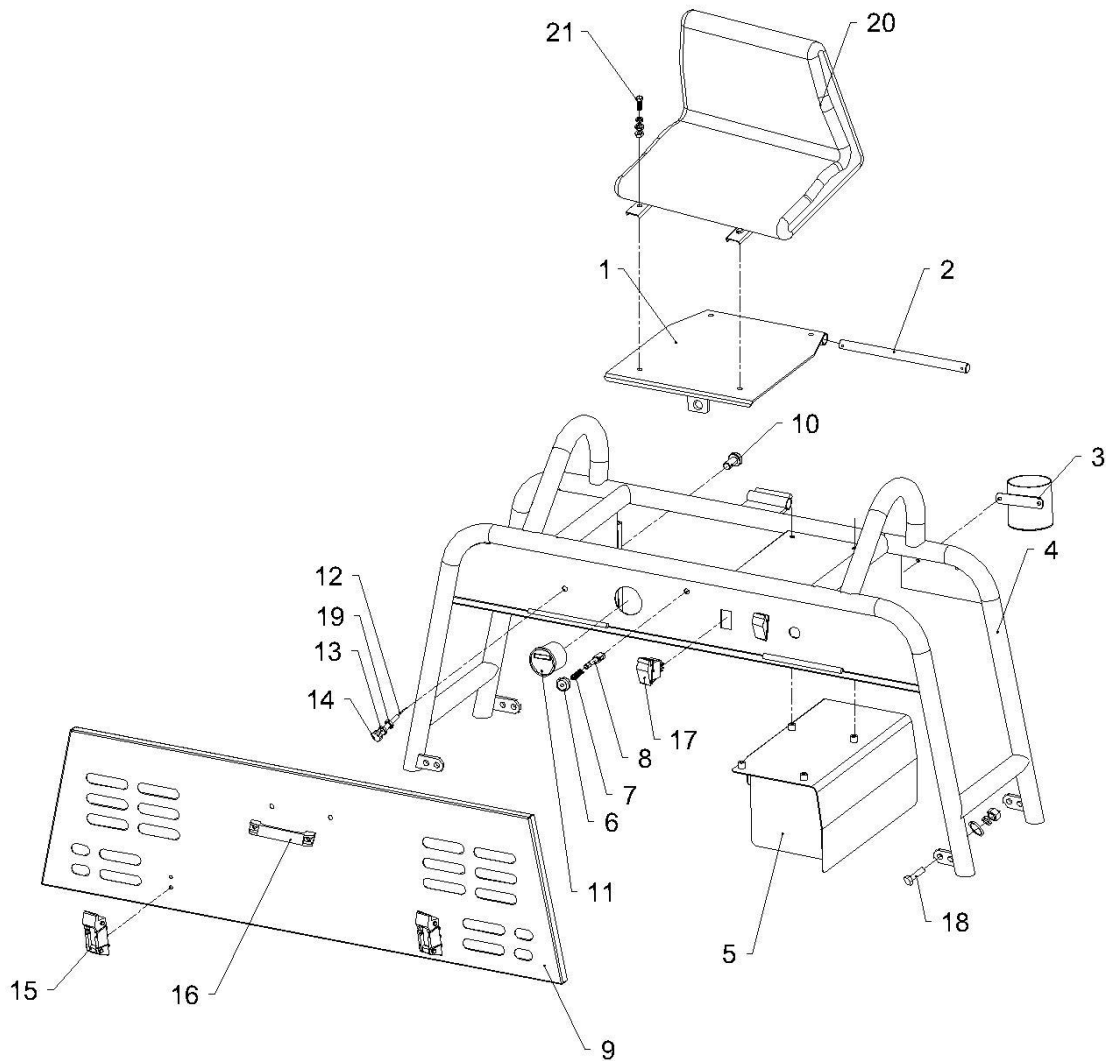



Solutions that last

M-B-W EUROPE LTD

Units 2 & 3 Cochrane Street, Bolton BL3 6BN

Tel: 01204 387784 Fax: 01204 387797

email: mbweurope@mbw.com > www.mbweurope.com

Item No.	Part No.	Description	Qty.
1	836G815	SEAT PLATE	1
2	B8360805	PIN	1
3	836G825	CUP HOLDER	1
4	836G800	UPPER FRAME	1
5	836G820	HEAT SHIELD	1
6	1046H8301	SEAT FASTENER	1
7	1046H8304	SPRING	1
8	1046H8302	PIN	1
9	836G819	FRONT PANEL	1
10	836G829	BOLT	1
11	9909	HOUR METER	1
12	JG846A080011	CHOKE CABLE	1
13	JG846A080012	CHOKE BUSHING	1
14	9907	CHOKE KNOB	1
15	9346	FRONT PANEL ACCESS MECHANISM	2
16	9678	Handle	1
17	9641	LIGHT SWITCH	2
18	9018	BOLT	8
	9091	NUT	8
	9922	WASHER	8
	9046	SPRING WASHER	8
19	9059	NUT	2
20	8360453	SEAT	1
21	9213A	BOLT	4
	9037	SPRING WASHER	4
	9038	WASHER	4
	9032	NUT	4





Solutions that last

M-B-W EUROPE LTD

Units 2 & 3 Cochrane Street, Bolton BL3 6BN

Tel: 01204 387784 Fax: 01204 387797

email: mbweurope@mbw.com > www.mbweurope.com

2. Guard Ring

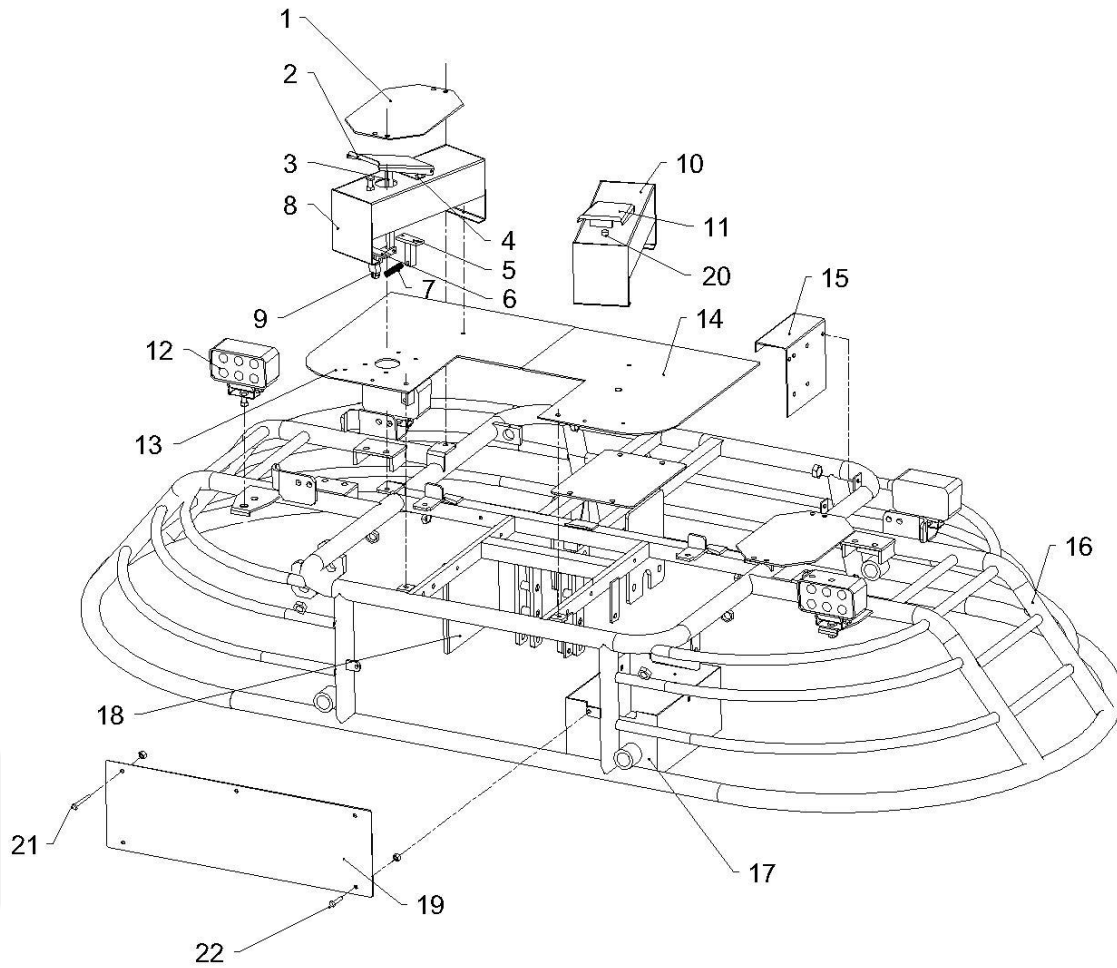



Solutions that last

M-B-W EUROPE LTD

Units 2 & 3 Cochrane Street, Bolton BL3 6BN

Tel: 01204 387784 Fax: 01204 387797

email: mbweurope@mbw.com > www.mbweurope.com

Item No.	Part No.	Description	Qty.
1	836G711	TANK PLATE	2
2	8360592a	THROTTLE PEDAL	1
3	836G701	CONNECTING ROD	1
4	8360592C	PEDAL CONNECTION PLATE	1
5	8361428	SUPPORT	1
6	8361426	SUPPORT	1
7	9411	SPRING	1
8	836G720	SUPPORT	1
9	8361427B	CONNECTING ROD	1
10	836G730	SUPPORT	1
11	8361062a	SAFETY SWITCH PEDAL	1
12	9970	LED LIGHT	4
13	836G831	FOOT PLATE	1
14	836G832	FOOT PLATE	1
15	B8360731	MOUNTING PLATE	1
16	836G100	GUARD RING	1
17	8360464	BATTERY BOX	1
18	836G833	PLATE	1
19	836G830	FRONT PANEL	1
20	9555	SAFETY SWITCH	1
21	9746	BOLT	3
	9023	NUT	3
22	9220	BOLT	2
	9023	NUT	2





Solutions that last

M-B-W EUROPE LTD

Units 2 & 3 Cochrane Street, Bolton BL3 6BN

Tel: 01204 387784 Fax: 01204 387797

email: mbweurope@mbw.com > www.mbweurope.com

3. Power System

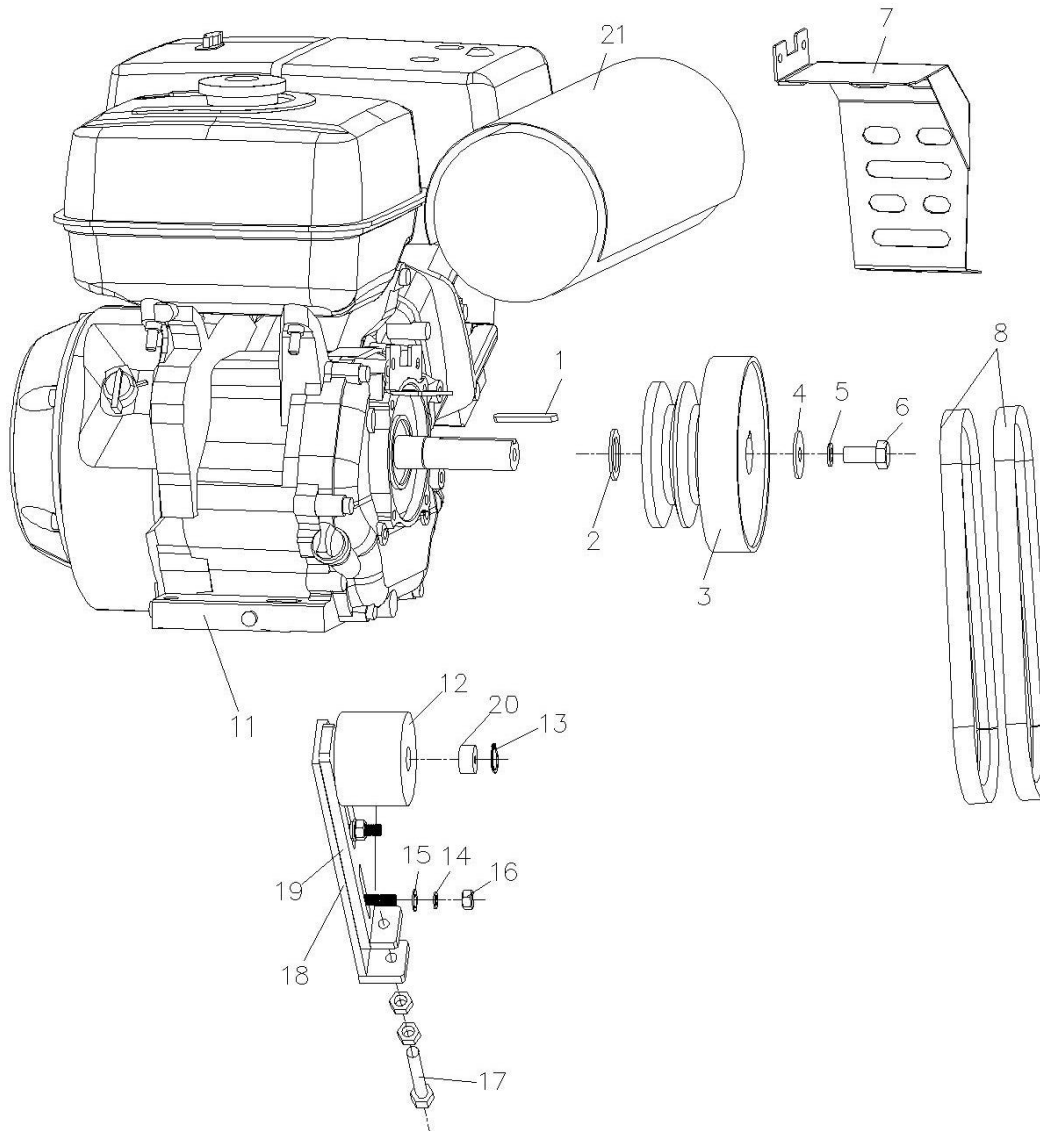



Solutions that last

M-B-W EUROPE LTD

Units 2 & 3 Cochrane Street, Bolton BL3 6BN

Tel: 01204 387784 Fax: 01204 387797

email: mbweurope@mbw.com ➤ www.mbweurope.com

Item No.	Part No.	Description	Qty.
1	9155	PIN	1
2	8360060	WASHER	1
3	8361815D	CLUTCH	1
4	JG846A030006	BUSHING	1
5	0064	SPRING WASHER	1
6	0529	BOLT	1
7	836G305	BELT GUARD	1
8	9974	BELT	2
11	31000037C	GX690	1
12	B8360327	TENSIONER	1
13	9027	RETAINER	1
14	9037	SPRING WASHER	2
15	9038	WASHER	10
16	9036	BOLT	4
17	9605	BOLT	1
18	836G300	MOUNTING PLATE	1
19	B8360325a	ADJUST PLATE	1
20	9063A	BEARING	2
21	31000026a	MUFFLER	1





Solutions that last

M-B-W EUROPE LTD

Units 2 & 3 Cochrane Street, Bolton BL3 6BN

Tel: 01204 387784 Fax: 01204 387797

email: mbweurope@mbw.com > www.mbweurope.com

Item No.	Part No.	Description	Qty.
1	836G420	BRACKET, RIGHT	1
2	836G425	CROSS SHAFT MOUNTING	4
3	9973	BUSHING	6
4	836G405	CROSS SHAFT	1
5	B8360433	SHAFT	1
6	836G407	MOUNTING BRACKET, RIGHT	1
7	836G403R	GEARBOX, RIGHT	1
8	B8360331	FLANGE	2
9	B8360330	COUPLING	2
10	B8360332	FLANGE	2
11	9601	BEARING	2
12	836G301	INTERMEDIATE SHAFT	1
13	B8360314L	PULLEY	1
14	836G410	BRACKET, LEFT	1
15	836G401	MOUNTING BRACKET, LEFT	1
16	836G403L	GEARBOX, LEFT	1
17	B8360470	PITCH HANDLE	2
18	4465502	BUSHING	2
19	4365504	SPACER	4
20	4365503	THREADED SHAFT	2
21	4465505	BUSHING	2
22	B8360465	CONNECTOR	2
23	B8360466	ROD	2
24	B8360467	CONNECTOR	2
25	9157A	PIN	4
26	9025	BEARING	2
27	9093	BOLT	2
	9022	SPRING WASHER	2
28	9027	RETAINER	2
29	9028	BOLT	2
30	9607	KEY	1
31	9608	KEY	2
32	9703	BOLT	4
	9259	NUT	4
33	9018	BOLT	28
	9046	SPRING WASHER	20
	9047	WASHER	8





Solutions that last

M-B-W EUROPE LTD

Units 2 & 3 Cochrane Street, Bolton BL3 6BN

Tel: 01204 387784 Fax: 01204 387797

email: mbweurope@mbw.com www.mbweurope.com

5. Operating System

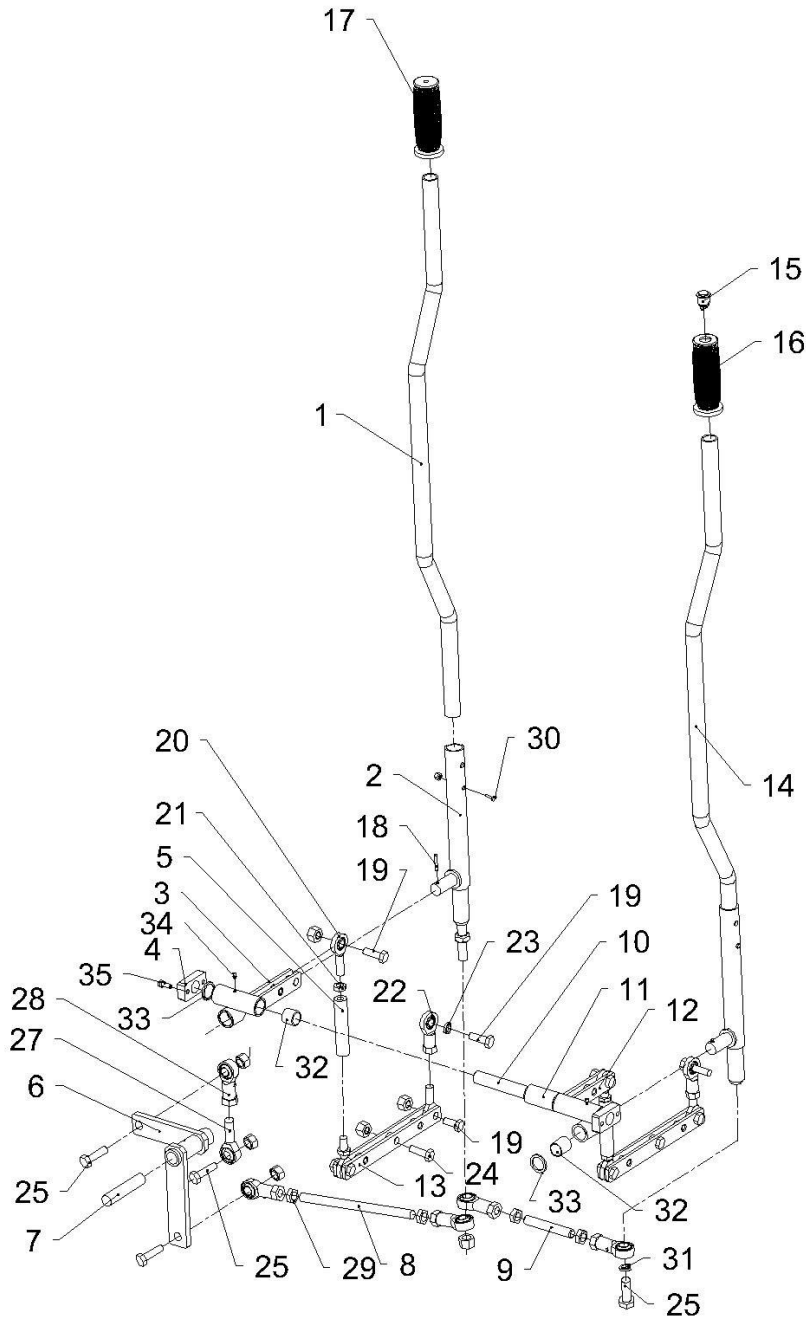



M-B-W EUROPE LTD

Units 2 & 3 Cochrane Street, Bolton BL3 6BN

Tel: 01204 387784 Fax: 01204 387797

email: mbweurope@mbw.com ➤ www.mbweurope.com

Solutions that last

Item No.	Part No.	Description	Qty.
1	836G220	DRIVE LEVER, RIGHT	1
2	836G205	DRIVE LEVER BASE	2
3	836G200R	CROSS BUSHING, RIGHT	1
4	836G226	SHAFT BASE	2
5	836G235	BUSHING	2
6	836G229	PLATE	1
7	836G232	SHAFT	1
8	836G233	ADJUST SHAFT	1
9	836G234	SHAFT	1
10	836G228	SHAFT	1
11	836G227	BUSHING	1
12	836G200L	CROSS BUSHING, LEFT	1
13	836G210	LEVER	2
14	836G222	DRIVE LEVER, LEFT	1
15	9910	WATER SPRAY BUTTON	1
16	9035G2	GRIP	1
17	9035G1	GRIP	1
18	9030	PIN	2
19	9703	BOLT	8
	9259	NUT	8
20	9944	BEARING	6
21	9168G	NUT	6
22	9945	BEARING	2
23	9509	SPRING WASHER	2
24	9507A	BOLT	2
	9259	NUT	8
25	9702A	BOLT	3
	9513	NUT	2
27	9500	BEARING	1
28	9501	BEARING	5
29	9514	NUT	4
30	9040A	BOLT	4
	9236	NUT	4
31	9504	SPRING WASHER	1
32	9972	BEARING	8
33	G223	SPACER	4
34	9502b	NIPPLE	2
35	9232	BOLT	4
	9038	WASHER	4
	9037	SPRING WASHER	4





M-B-W EUROPE LTD

Units 2 & 3 Cochrane Street, Bolton BL3 6BN

Tel: 01204 387784 Fax: 01204 387797

email: mbweurope@mbw.com > www.mbweurope.com

Solutions that last

6. Gearbox Assembly (Left)

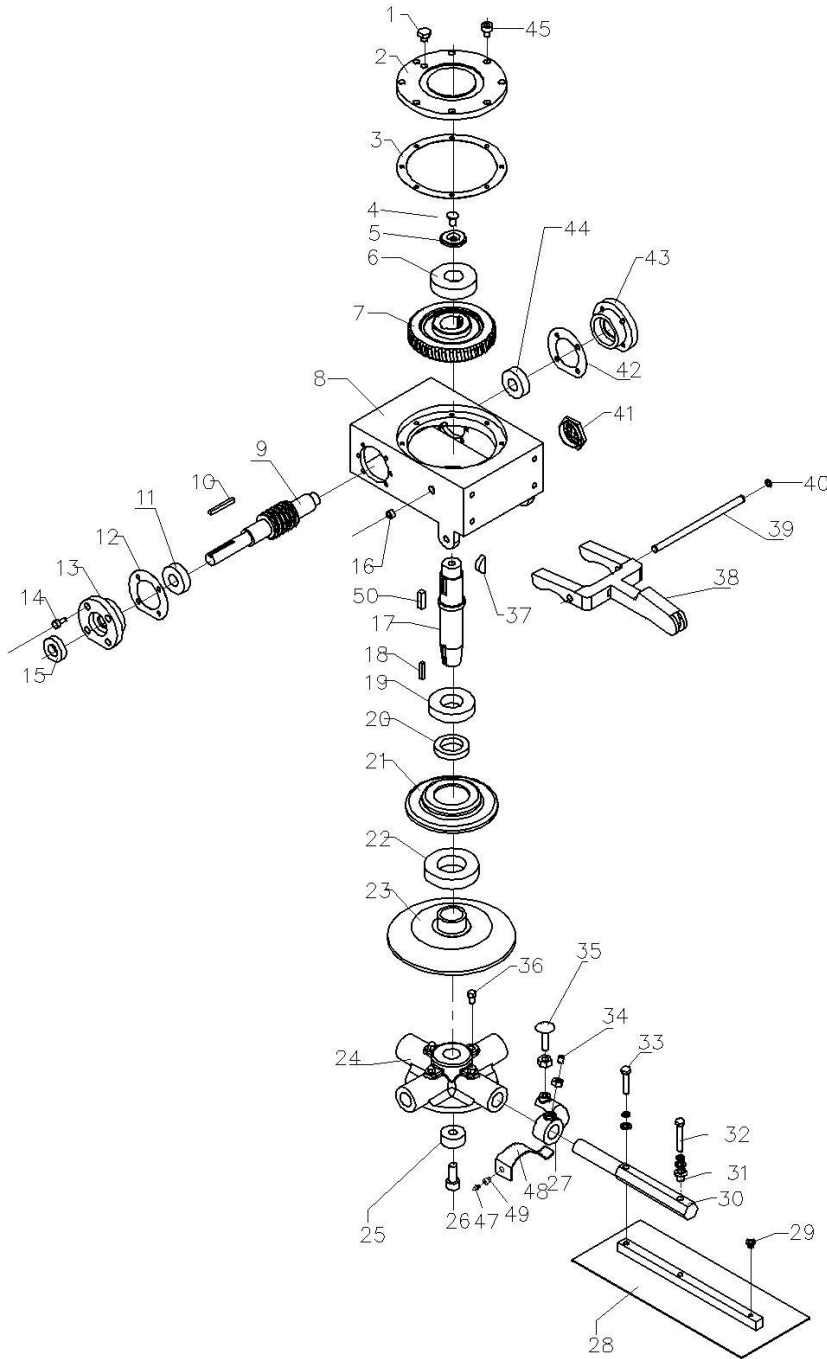



M-B-W EUROPE LTD

Units 2 & 3 Cochrane Street, Bolton BL3 6BN

Tel: 01204 387784 Fax: 01204 387797

email: mbweurope@mbw.com ➤ www.mbweurope.com

Solutions that last

Item No.	Part No.	Description	Qty.
1	4364100	RELEASE VALVE	2
2	8364005	GEARBOX COVER	1
3	4464008	SHIMMING	2
4	4364007	BOLT	1
5	4364006	PRESSURE WASHER	1
6	9144	BEARING	1
7	8364010L	BRONZE GEAR, LEFT	1
8	836G403L	GEARBOX CASING, LEFT	1
9	B8364013L	COUNTER SHAFT, LEFT	1
10	9611	KEY	1
11	9143	BEARING	1
12	4464015	SHIMMING	1
13	4464012	BEARING FLANGE	1
14	9043	BOLT	12
15	9055	SEAL	1
16	9053	PLUG	2
17	8364011L	MAIN SHAFT, LEFT	1
18	9154	KEY	1
19	9222A	BEARING	1
20	9153	SEAL	1
21	4466002	PRESSURE PLATE COVER	1
22	9140	BEARING	1
23	8366003	PRESSURE PLATE	1
24	8366005L	SPIDER PLATE, LEFT	1
25	4466004	BUSHING	1
26	9068	BOLT	1
27	4466006	LIFT LEVER	4
28	4366100G	BLADE	4
29	9072	PLUG	4
30	8366001	TROWEL ARM	4
31	4366007a	BUSHING	4
32	9215	BOLT	4
	9037	SPRING WASHER	4
	9038	WASHER	4
33	9040	BOLT	4





M-B-W EUROPE LTD

Units 2 & 3 Cochrane Street, Bolton BL3 6BN

Tel: 01204 387784 Fax: 01204 387797

email: mbweurope@mbw.com > www.mbweurope.com

Solutions that last

	9037	SPRING WASHER	4
	9038	WASHER	4
34	9540	BOLT	4
	9059	NUT	4
35	9067	BOLT	4
	9059	NUT	4
36	9066	BOLT	4
37	9156	KEY	1
38	B8365510	YOKE ARM	1
39	4465509	SHAFT, YOKE ARM	1
40	9202	RETAINER	2
41	9064	GLASS EYE	1
42	4464015	SHIMMING	1
43	4464014	BEARING FLANGE	1
44	9141	BEARING	1
45	9118	BOLT	8
47	9502	NIPPLE	4
48	8366007L	RETURNING SPRING	4
49	8366008	BUSHING	4
50	9531	KEY	1





M-B-W EUROPE LTD

Units 2 & 3 Cochrane Street, Bolton BL3 6BN

Tel: 01204 387784 Fax: 01204 387797

email: mbweurope@mbw.com > www.mbweurope.com

Solutions that last

7. Gearbox Assembly (Right)

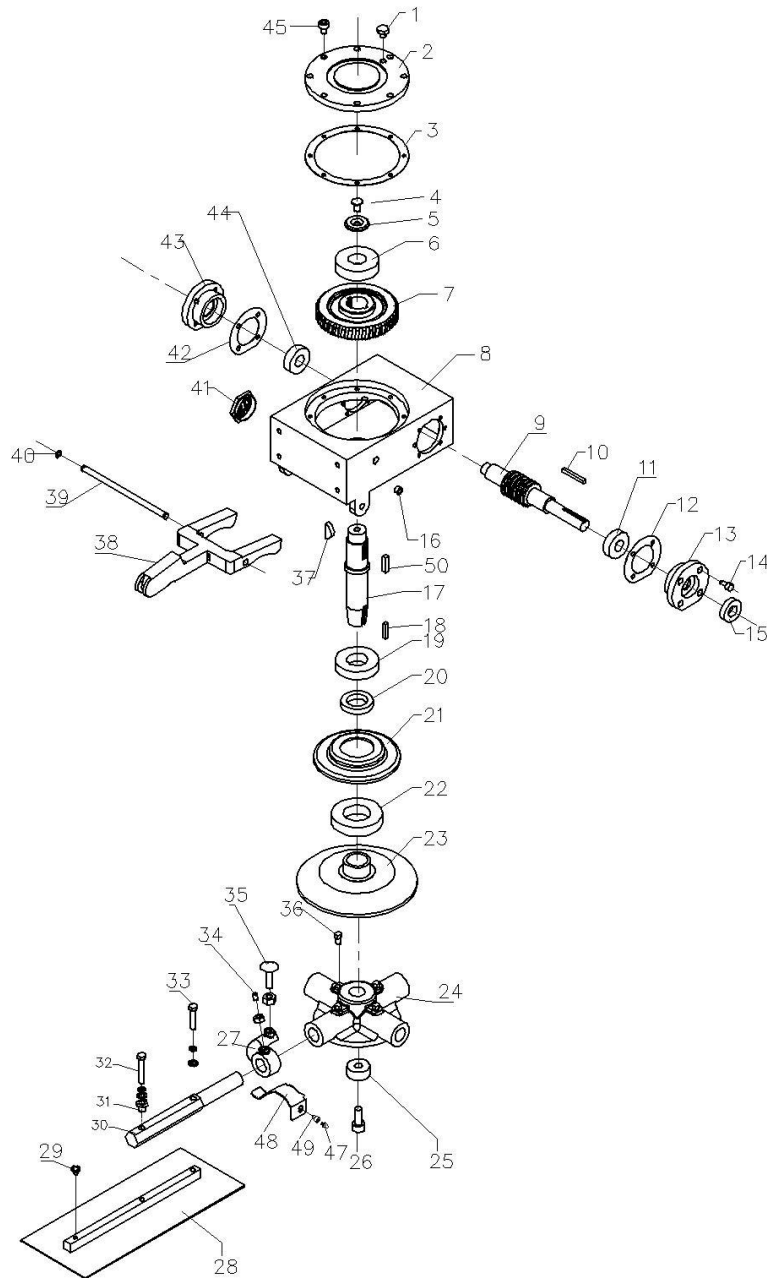



M-B-W EUROPE LTD

Units 2 & 3 Cochrane Street, Bolton BL3 6BN

Tel: 01204 387784 Fax: 01204 387797

email: mbweurope@mbw.com > www.mbweurope.com

Solutions that last

Item No.	Part No.	Description	Qty.
1	4364100	RELEASE VALVE	2
2	8364005	GEARBOX COVER	1
3	4464008	SHIMMING	2
4	9145	BOLT	1
5	4364006	PRESSURE WASHER	1
6	9144	BEARING	1
7	8364010R	BRONZE GEAR, RIGHT	1
8	836G403R	GEARBOX CASING, RIGHT	1
9	B8364013R	COUNTER SHAFT, RIGHT	1
10	9611	KEY	1
11	9143	BEARING	1
12	4464015	SHIMMING	1
13	4464012	BEARING FLANGE	1
14	9043	BOLT	12
15	9055	SEAL	1
16	9053	PLUG	2
17	8364011R	MAIN SHAFT, RIGHT	1
18	9154	KEY	1
19	9222A	BEARING	1
20	9153	SEAL	1
21	4466002	PRESSURE PLATE COVER	1
22	9140	BEARING	1
23	8366003	PRESSURE PLATE	1
24	8366005R	SPIDER PLATE, RIGHT	1
25	4466004	BUSHING	1
26	9068	BOLT	1
27	8366006	LIFT LEVER	4
28	4366100G	BLADE	4
29	9072	PLUG	4
30	8366001	TROWEL ARM	4
31	4366007a	BUSHING	4
32	9215	BOLT	4
	9037	SPRING WASHER	4
	9038	WASHER	4
33	9040	BOLT	4





M-B-W EUROPE LTD

Units 2 & 3 Cochrane Street, Bolton BL3 6BN

Tel: 01204 387784 Fax: 01204 387797

email: mbweurope@mbw.com > www.mbweurope.com

Solutions that last

	9037	SPRING WASHER	4
	9038	WASHER	4
34	9540	BOLT	4
	9059	NUT	4
35	9067	BOLT	4
	9059	NUT	4
36	9066	BOLT	4
37	9156	KEY	1
38	B8365510	YOKE ARM	1
39	4465509	SHAFT, YOKE ARM	1
40	9202	RETAINER	2
41	9064	GLASS EYE	1
42	4464015	SHIMMING	1
43	4464014	BEARING FLANGE	1
44	9141	BEARING	1
45	9118	BOLT	8
47	9502	NIPPLE	4
48	8366007R	RETURNING SPRING	4
49	8366008	BUSHING	4
50	9531	KEY	1





M-B-W EUROPE LTD

Units 2 & 3 Cochrane Street, Bolton BL3 6BN

Tel: 01204 387784 Fax: 01204 387797

email: mbweurope@mbw.com > www.mbweurope.com

Solutions that last

8. Fuel & Water system

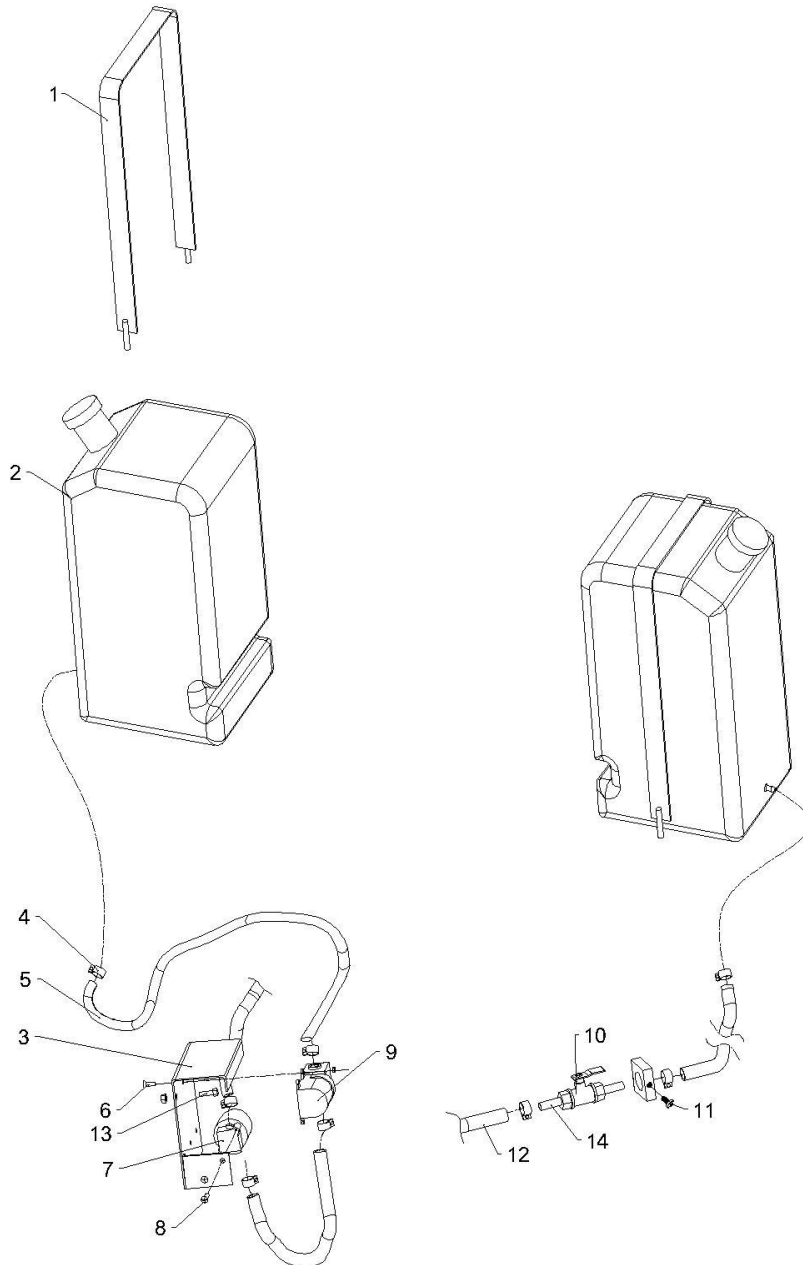



Solutions that last

M-B-W EUROPE LTD

Units 2 & 3 Cochrane Street, Bolton BL3 6BN

Tel: 01204 387784 Fax: 01204 387797

email: mbweurope@mbw.com > www.mbweurope.com

Item No.	Part No.	Description	Qty.
1	FT8360710	TANK HOOP	2
2	B8361073PL	WATER/FUEL TANK	2
3	B8360731	MOUNTING PLATE	1
4	8361071	JOINT	12
5	10202003	WATER PIPE	1
6	9516	BOLT	4
	9517	NUT	4
7	8361142	SOLENOID PILOT ACTUATED VALVE	1
8	9230	BOLT	2
	9128	SPRING WASHER	2
	9038	WASHER	2
9	8361067	WATER PUMP	1
10	8361476	VALVE	1
11	9010	BOLT	1
12	10202004	FUEL PIPE	1
13	9902	BOLT	4
	9023	NUT	4
14	8361476A	JOINT	2



WARRANTY

1. **MBW** warrants each new machine against defects in material and workmanship under normal use and service for a period of six (6) months. This warranty commences the first day the machine is sold, assigned to a rental fleet, or otherwise put to first use.
2. The obligation under this warranty is limited to the replacement or repair of parts and/or machine at **MBW** factory branches or at authorized **MBW** distributors.
3. Machines altered or modified without **MBW** written consent voids this warranty. Misuse, negligence, accidents or the operation of machines in any way other than recommended by **MBW** will void this warranty. This warranty shall not apply to machines repaired by other than **MBW** factory branches or authorized **MBW** distributors.
4. This warranty includes labor on all **MBW** products. Labor must be performed at an authorized **MBW** distributor.
5. The cost of transportation and other expenses connected therewith are not covered by this warranty.
6. Written authorization for the return of merchandise under warranty must be obtained from **MBW** or **MBW (UK) Limited**.
7. **MBW** reserves the right to inspect and render final decision on each warranty case.
8. **MBW** reserves the right to improve or make product changes without incurring any obligation to update, refit, or install the same on machines previously sold.
9. **MBW** is not responsible for any liability or damage or injury directly or indirectly from design, material or operation of its products.
10. Warranty card must be returned to **MBW** or **MBW (UK) Limited** within 10 days after purchase, assignment to a rental fleet, or first use. Failure to return warranty card as specified renders the warranty null and void.
11. Requests for warranty must be submitted within 30 days after machine failure to **MBW** or **MBW (UK) Limited**.
12. The foregoing warranty is expressly in lieu of all other warranties, expressed or implied, including the warranties of merchantability and fitness for use, and of all other obligation or liabilities on our part, and we neither assume nor authorize any other person to assume for us any other liability or warranty in connection with the sale or service of any of our products. Likewise, this warranty shall not apply with respect to engines, motors and other component parts produced by other manufactures and used on **MBW** products, but such items shall have such warranties as may be provided by the manufacturer thereof.



MBW, Inc.
250 Hartford Rd • PO Box 440
Slinger, WI 53086-0440
Phone: (262) 644-5234
Fax: (262) 644-5169
Email: mbw@mbw.com
Website: www.mbw.com

MBW EUROPE Ltd.
Units 2 & 3 Cochrane Street
Bolton BL3 6BN, England
Phone: 01204 387784
Fax: 01204 387797