

VIBRATORY PLATES



[AP12 | GP12 | AP15 | GP15 | AP18 | GP18]

[AP2000 | GP2000 | E2000]

[AP3550 | GP3550]

[GP5800]



BUILDING A BETTER JOBSITE EXPERIENCE



MBW.COM



FEATURES

MBW's advancements in vibratory plates have revolutionized the field over the past 50 years. Each model offers a unique combination of frequency, centrifugal force, amplitude and mass that have doubled productivity, dramatically reduced maintenance, and extended product life.

- Unsurpassed exciter quality including extra heavy duty housings, oversized application matched bearings, and an oil mist lubrication system to withstand high operating temperatures.
- Application matched quality shock mounts and double isolated guide handles.



1000 SERIES



This series of economical vibratory plates, the **12, 15 & 18**, are portable, and offer outstanding compaction performance. A patented suspension system places shock mounts in a predominantly shear mode at the high amplitude front end of the plate and a predominantly compressive mode at the low amplitude trailing end of the plate. This system reduces hand arm vibration and also better isolates all upper mass components, including the engine, from vibrations produced by the machine's exciter. With amplitudes up to .063 inches, centrifugal force up to 2780 lbs and travel speeds to 83 feet per minute these plates are ideal in confined areas of granular soils including sands and gravel.

These lightweight plates weighing 137 lbs (62 kg) to 183 lbs (83 kg), without water, are easy to lift and maneuver about the job site. Accompanied by intense vibration, this series of plates are ideally suited as an economical alternative for small to medium compaction applications.

MBW.COM

- Standard with Honda engine and lift cage
- One piece exciter with self cleaning open base plate design
- Patented isolation system
- Optional wheel kit
- Optional UHMW paving pad for placing interlocking paving stone/brick/block



OPTIONAL WHEEL KIT



OPTIONAL UHMW PAD

MODEL	GP12	GP15	GP18
Plate Size WxL	13 x 22.5 in (33 x 57 cm)	16 x 22.5 in (40 x 57 cm)	18 x 22.5 in (46 x 57 cm)
Operating Weight	137 lbs (62 kg)	145 lbs (66 kg)	174 lbs (79 kg)
Engine	Honda GX120	Honda GX120	Honda GX160
Amplitude	.055 in (1.40 mm)	.052 in (1.32 mm)	.063 in (1.59 mm)
Centrifugal Force**	1920 lbs (8.5 kN)	2000 lbs (8.9 kN)	2780 lbs (12.3 kN)
Exciter Speed	5240 vpm	5350 vpm	5240 vpm
Compaction Depth*	Up to 10 in (25 cm)	Up to 10 in (25 cm)	Up to 10 in (25 cm)
Travel Speed	up to 83 ft/min (25 m/min)	up to 68 ft/min (21 m/min)	up to 75 ft/min (23 m/min)
Compaction Area	5395 ft ² /hr (501 m ² /hr)	5440 ft ² /hr (505 m ² /hr)	6750 ft ² /hr (627 m ² /hr)

MODEL	AP12	AP15	AP18
Plate Size WxL	13 x 22.5 in (33 x 57 cm)	16 x 22.5 in (40 x 57 cm)	18 x 22.5 in (46 x 57 cm)
Operating Weight	No Water 139 lbs (63 kg) Full Water 158 lbs (72 kg)	No Water 147 lbs (67 kg) Full Water 166 lbs (75 kg)	No Water 183 lbs (83 kg) Full Water 202 lbs (92 kg)
Engine	Honda GX120	Honda GX120	Honda GX160
Amplitude (No Water)	.054 in (1.38 mm)	.051 in (1.30 mm)	.060 in (1.51 mm)
Centrifugal Force**	1920 lbs (8.5 kN)	2000 lbs (8.9 kN)	2780 lbs (12.3 kN)
Exciter Speed	5240 vpm	5350 vpm	5240 vpm
Compaction Depth*	Up to 10 in (25 cm)	Up to 10 in (25 cm)	Up to 10 in (25 cm)
Travel Speed	up to 83 ft/min (25 m/min)	up to 68 ft/min (21 m/min)	up to 75 ft/min (23 m/min)
Compaction Area	5395 ft ² /hr (501 m ² /hr)	5440 ft ² /hr (505 m ² /hr)	6750 ft ² /hr (627 m ² /hr)
Water Tank Capacity	2.3 gal (8.7 l)	2.3 gal (8.7 l)	2.3 gal (8.7 l)

* Clean sand, optimum moisture. MBW recommends that lifts not exceed 12".
 ** Centrifugal Force is not a measure of compaction performance.
 () Metric Measurements. Specifications subject to change without notice.

2000 SERIES



MBW's **AP2000** was the first vibratory plate compactor specifically designed for asphalt applications.

Stress relieved steel plates are crack resistant and provide long wear. Aluminum exciter housing dissipates heat rapidly and custom lubricants preserve bearing and seal integrity.

- Optional UHMW paving pad accessory for interlocking paving blocks
- Optional wheel kit

The **GP2000** is designed to provide optimal productivity in compaction of sands and gravel; does not include a water tank.

- Optional UHMW paving pad accessory for placing interlocking paving stone/brick/block
- Optional wheel kit



MODEL	AP2000	GP2000
Plate Size WxL	20 x 22 in (51 x 56 cm)	20 x 22 in (51 x 56 cm)
Operating Weight	168 lbs (76 kg) <i>No Water</i> 193 lbs (88 kg) <i>Full Water</i>	165 lbs (75 kg)
Engine Options	Honda GX160	Honda GX160
Amplitude	.082 in (2.08 mm) <i>No Water</i> .071 in (1.80 mm) <i>Full Water</i>	.083 in (2.11 mm)
Centrifugal Force**	2475 lbs (11 kN)	3250 lbs (14.5 kN)
Exciter Speed	4400 vpm	5050 vpm
Compaction Depth*	Up to 12 in (31 cm)	Up to 12 in (31 cm)
Travel Speed	up to 90 ft/min (27 m/min)	up to 120 ft/min (37 m/min)
Compaction Area	9000 ft ² /hr (836 m ² /hr)	12000 ft ² /hr (1115 m ² /hr)
Water Tank Capacity	3 gal (11.3 l)	N/A

* Clean sand, optimum moisture. MBW recommends that lifts not exceed 12".

** Centrifugal Force is not a measure of compaction performance.

() Metric Measurements. Specifications subject to change without notice.



OPTIONAL UHMW PAVING PAD FOR INTERLOCKING PAVING BLOCKS

OPTIONAL WHEEL KIT

THE HEART AND SOUL

of our machines are their rugged, hard hitting exciters. Our exciters include an extra **heavy duty housing** with maximum surface area for heat dissipation and strength, and **ductile eccentric shafts** that are precision ground to preserve bearing tolerances. The **bearings are carefully matched** in design, tolerance and type for high temperature vibratory applications and **custom lubricants** with elevated flash points. Nowhere in the world will you find a stronger or more dependable driving force behind a vibratory plate.

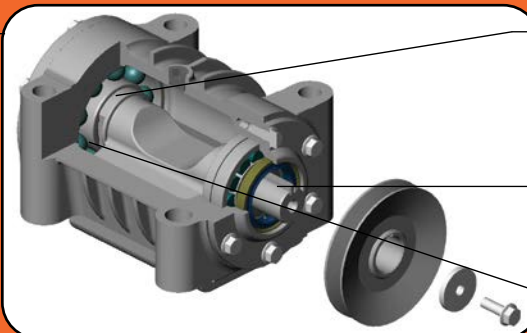

HEAVIEST BEARINGS

in the industry to maintain performance and minimize down time

PRECISION MACHINED SHAFT

to maintain critical bearing tolerances

LUBRICANTS

for high temperature applications

3000 SERIES



THE GP3550 is a high production compactor that will run decades with reasonable maintenance. The deck features a full roll cage as standard equipment with provisions for a water tank for asphalt compaction on the AP3550. Both models provide reduced hand/arm vibration, full roll cage protection, enhanced amplitude, faster travel speed and updated yet rugged appearance.



5000 SERIES



The GP5800 is an upgrade of model GP5500. The GP5800 maintains its predecessor's outstanding performance characteristics while improving the design in terms of ergonomics, ease of service and product life expectations. Among these are a removable, easily serviced exciter assembly for improved engine isolation, lower hand/arm vibration and standard protective cage surrounding the engine. This high production compactor travels up to 130 ft/min, generates .094 inch amplitude for deep penetration of backfill materials and is unmatched on mid-sized to large commercial and infrastructure applications.

MODEL	AP3550	GP3550
Plate Size WxL	21 x 22 in (53 x 56 cm)	
Weight	No Water 229 lbs (104 kg) Full Water 254 lbs (115 kg)	226 lbs (103 kg)
Engine	Honda GX160	
Amplitude	.086 in (2.2 mm)	.087 in (2.2 mm)
Centrifugal Force**	3550 lbs (15.8 kN)	
Exciter Speed	4400 vpm	
Compaction Depth*	Up to 18 in (46 cm)	Up to 18 in (46 cm)
Travel Speed	up to 110 ft/min (34 m/min)	up to 110 ft/min (34 m/min)
Compaction Area	11550 ft ² /hr (1073 m ² /hr)	11550 ft ² /hr (1073 m ² /hr)

* Clean sand, optimum moisture. MBW recommends that lifts not exceed 12".
 ** Centrifugal Force is not a measure of compaction performance.
 () Metric Measurements. Specifications subject to change without notice.

MODEL	GP5800
Plate Size WxL	23 x 24 in (58 x 61 cm)
Weight	289 lbs (131 kg)
Engine	Honda GX270
Amplitude	.094 in (2.39 mm)
Centrifugal Force**	5800 lbs (25.8 kN)
Exciter Speed	4800 vpm
Compaction Depth*	Up to 20 in (51 cm)
Travel Speed	up to 130 ft/min (39.6 m/min)
Compaction Area	14950 ft ² /hr (1389 m ² /hr)

* Clean sand, optimum moisture. MBW recommends that lifts not exceed 12".
 ** Centrifugal Force is not a measure of compaction performance.
 () Metric Measurements. Specifications subject to change without notice.



MBW, INC.
 250 Hartford Road • P.O. Box 440
 Slinger, Wisconsin • 53086-0440 • USA
 800-678-5237 • Service: 262-644-7686
 E-mail: mbw@mbw.com • Website: www.mbw.com

AUTHORIZED DISTRIBUTOR