

R670H TRENCH RAMMER

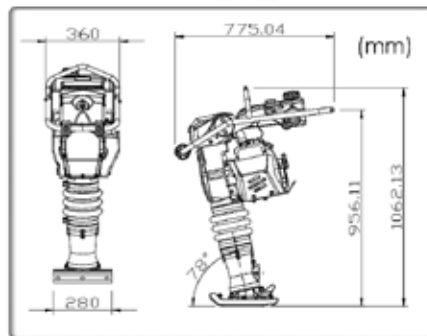

POWERED by HONDA

Available in 3 sizes

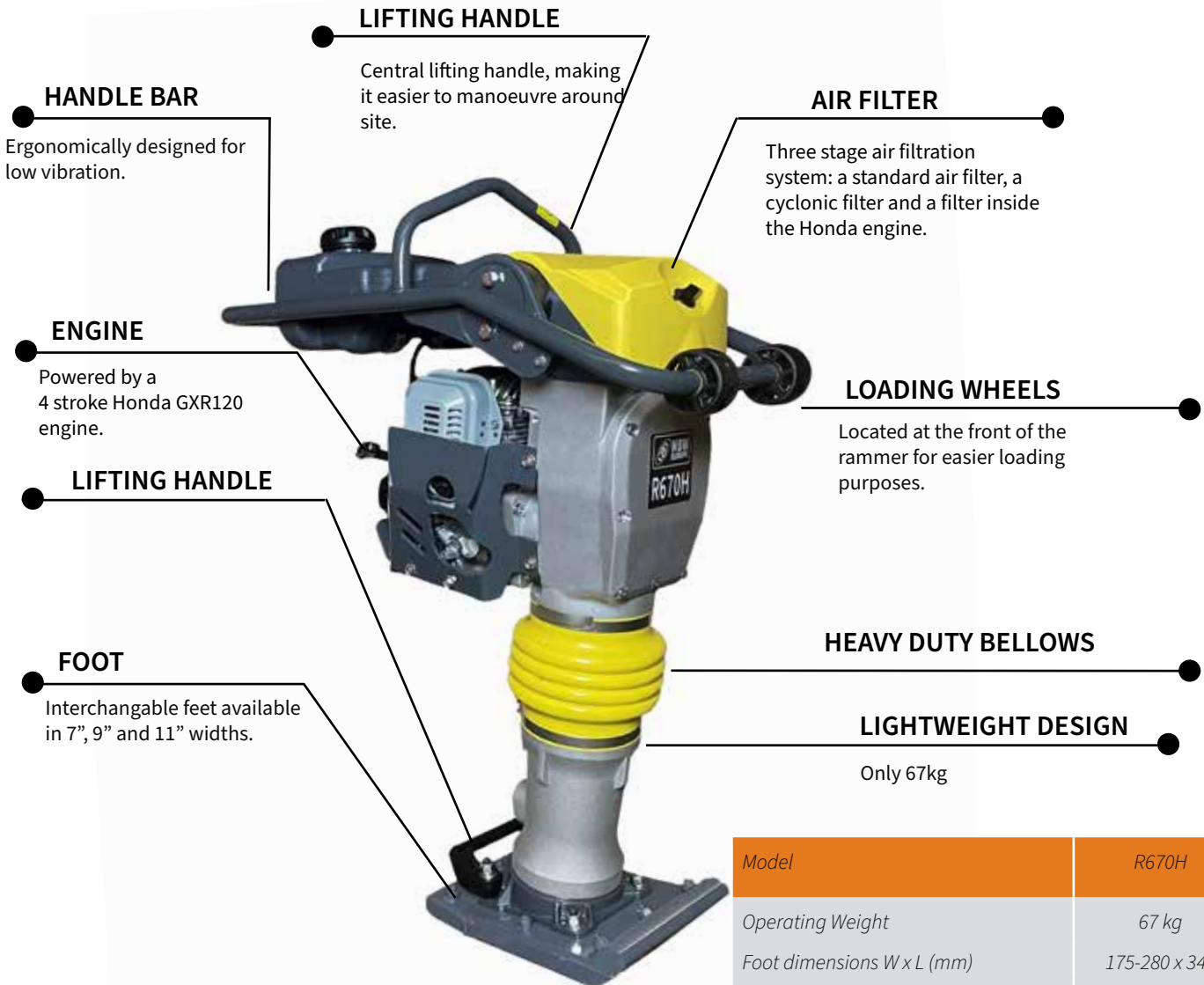

280mm 230mm 175mm



Model	R670H
Operating Weight	67 kg
Foot dimensions W x L (mm)	175-280 x 340
Engine	Honda GXR120
Power hp (kW)	3.1 (2.3)
Engine Speed (rpm)	3600
Cylinder (cm ³)	121
Consumption of fuel (h/l)	1.1
Amplitude (mm)	70-85
Frequency (Hz)	12
Centrifugal Force (kN)	18
Sound Pressure Level dB (A)	104
Percussion Rate Max. (blows/min)	640
Operating Speed (m/min)	8-11
Surface Capacity Compaction (m ² /h)	149