

OPERATOR'S SAFETY AND SERVICE MANUAL



F36 & F46

This manual covers the following serial numbers and higher, for each model listed:

F46/4	1470130.
F36/4	1370020.
Power Pitch	PP10000



WALK-BEHIND HIGH TORQUE TROWEL

MBW, Inc.
250 Hartford Rd • PO Box 440
Slinger, WI 53086-0440
Phone: (262) 644-5234
Fax: (262) 644-5169
Email: mbw@mbw.com
Website: www.mbw.com

MBW Europe Ltd.
Units 2&3 Cochrane Street
Bolton BL3 6BN
England, UK
Phone: +44 (0) 1204 387784
Fax: +44 (0) 1204 387797
Email: saleseurope@mbw.com
Website: mbw-europe.com

L20709.12.23.P
©MBW, Inc. 2023
Printed in the USA

TABLE OF CONTENTS

SAFETY INFORMATION	1	Changing Trowel Blades	8
Introduction	1	Setting Tilt Arm Carriage Bolt Height	8
Safety Precautions	1	Replacing Power Pitch Fuse	8
Safety Decals	1	Adjusting Power Pitch Actuator	8
Safety Decals - EZ Pitch/Low vibration Handle	3		
SPECIFICATIONS	4	SERVICE	10
OPERATION	5	Torque Chart	10
Introduction	5	Service Tools	10
Before Starting & Operating	5	Gearbox Disassembly	10
Starting Engine	5	Gearbox Assembly	10
Operating	5	Handle Removal/Installation	11
Blade Pitch Adjustment (Standard)	5	Gas Spring Replacement	11
Blade Pitch Adjustment (Power Pitch)	5	Low Vibration handle Cable Replacement	12
Blade Pitch Adjustment (EZ Pitch)	5	Shorting Wire Replacement	12
Handle Height Adjustment (Low Vibration)	5	High Speed Clutch Spring Replacement	12
(Standard & EZ Pitch Handle)	6	Spider Bushing Removal	13
Stopping Engine	6	Power Pitch Actuator Replacement	13
		Spider Bushing Replacement	13
		Parts Replacement Cycles and Tolerances	13
MAINTENANCE	7	REPLACEMENT PARTS	15
Maintenance Schedule	7	Gearbox Assembly	16
Fluid Levels	7	Spider Assembly	18
Engine Maintenance	7	Drive Assembly	20
Engine Oil	7	Guard Assembly	22
Engine Speed	7	Standard Handle Assembly	24
Cleaning	7	Low Vibration Handle Assembly	26
Lubrication	7	EZ Pitch Handle Assembly	28
Lifting	8	Power Pitch Actuator & Wiring	30
Storage	8	Power Pitch Switch & Battery	32
Setting Safety Switch	8		
		WARRANTY	34



WARNING



CALIFORNIA PROPOSITION 65 WARNING

Engine exhaust and some of its constituents and dust produced during the use of this product contain chemicals known in the state of California to cause cancer, birth defects, and other reproductive harm.

SAFETY INFORMATION

Introduction



This Safety Alert Symbol is used to call attention to items or operations which may be dangerous to those operating or working with this equipment. The symbol can be found throughout this manual and on the unit. Please read these warnings and cautions, along with all decals, carefully before attempting to operate the unit. Make sure every individual who operates or works with this equipment is familiar with all safety precautions.

WARNING

GENERAL WARNING. Indicates information important to the proper operation of the equipment. Failure to observe may result in damage to the equipment and/or severe bodily injury or death.

CAUTION

GENERAL CAUTION. Indicates information important to the proper operation of the equipment. Failure to observe may result in damage to the equipment.

Safety Precautions



LETHAL EXHAUST GAS: An internal combustion engine discharges carbon monoxide, a poisonous, odorless, invisible gas. Death or serious illness may result if inhaled. Operate only in an area with proper ventilation. **NEVER OPERATE IN A CONFINED AREA!**



DANGEROUS FUELS: Use extreme caution when storing, handling and using fuels, as they are highly volatile and explosive in vapor state. Do not add fuel while engine is running. Stop and cool the engine before adding fuel. **DO NOT SMOKE!**



SAFETY GUARDS: It is the owner's responsibility to ensure that all guards and shields are in place and in working order.



IGNITION SYSTEMS: Breakerless, magneto, and battery ignition systems can cause severe electrical shocks. Avoid contacting these units or their wiring.



SAFE DRESS: Do not wear loose clothing, rings, wristwatches, etc. near machinery.



NOISE PROTECTION: Wear OSHA specified hearing protection devices.



EYE PROTECTION: Wear OSHA specified eye shields, safety glasses, and sweat bands.



HEAD PROTECTION: Wear OSHA specified safety helmets.



DUST PROTECTION: Wear OSHA specified dust mask or respirator.



OPERATOR: Keep children and bystanders off and away from the equipment.

REFERENCES: For details on safety rules and regulations in the United States, contact your local Occupational Safety and Health Administration (OSHA) office. Equipment operated in other countries must be operated and serviced in accordance and compliance with any and all safety requirements of that country. The publication of these safety precautions is done for your information. MBW does not by the publication of these precautions, imply or in any way represent that these are the sum of all dangers present near MBW equipment. If you are operating MBW equipment, it is your responsibility to insure that such operation is in full accordance with all applicable safety requirements and codes. All requirements of the United States Federal Occupational Safety and Health Administration Act must be met when operated in areas that are under the jurisdiction of that United States Department.

Safety Decals

Carefully read and follow all safety decals. Keep them in good condition. If decals become damaged, replace as required. If repainting the unit, replace all decals. Decals are available from authorized MBW distributors. Order the decal set listed on the following page(s).

WARNING Start engine at idle only!
NEVER place foot on guard ring.

12265

WARNING
OPERATION OF THIS EQUIPMENT MAY
CREATE SPARKS THAT CAN START FIRES
AROUND DRY VEGETATION. A SPARK
ARRESTER MAY BE REQUIRED. THE
OPERATOR SHOULD CONTACT LOCAL FIRE
AGENCIES FOR LAWS OR REGULATIONS
RELATING TO FIRE PREVENTION.

1791

MBW POWER TROWEL

21192

WARNING

IMPROPER PAN SIZE MAY CAUSE
INJURY OR DAMAGE. PAN OUTSIDE
DIAMETER NOT TO EXCEED
DIMENSIONS LISTED BELOW.

36" TROWEL PAN - 36.50" MAX. DIA.
46" TROWEL PAN - 43.75" MAX. DIA.

21689

WARNING

Operating, servicing and maintaining this equipment
can expose you to chemicals, including engine
exhaust, phthalates and lead, which are known to the
state of California to cause cancer and birth defects or
other reproductive harm. Avoid breathing engine
exhaust. Do not operate equipment in confined areas.
For more information go to www.P65Warnings.ca.gov

21820



21748

CAUTION

Read Operating Instructions before
operating this piece of equipment.
Keep unauthorized and untrained
people away from this equipment.
ROTATING & MOVING PARTS!
Make sure all guards and safety
devices are in place.
Wear OSHA approved hearing
protection, foot protection, eye
protection and head protection.
Avoid breathing dust from operating
machine, wear OSHA specified dust
mask/respirator.
SHUT OFF the motor before servicing
or cleaning.
DO NOT RUN in an enclosed area.
The engine produces carbon
monoxide, a **POISONOUS GAS**.
Failure to comply could result in serious bodily
injury.

13483

**F46
POWER TROWEL**

19962 - 36"

19963 - 46"

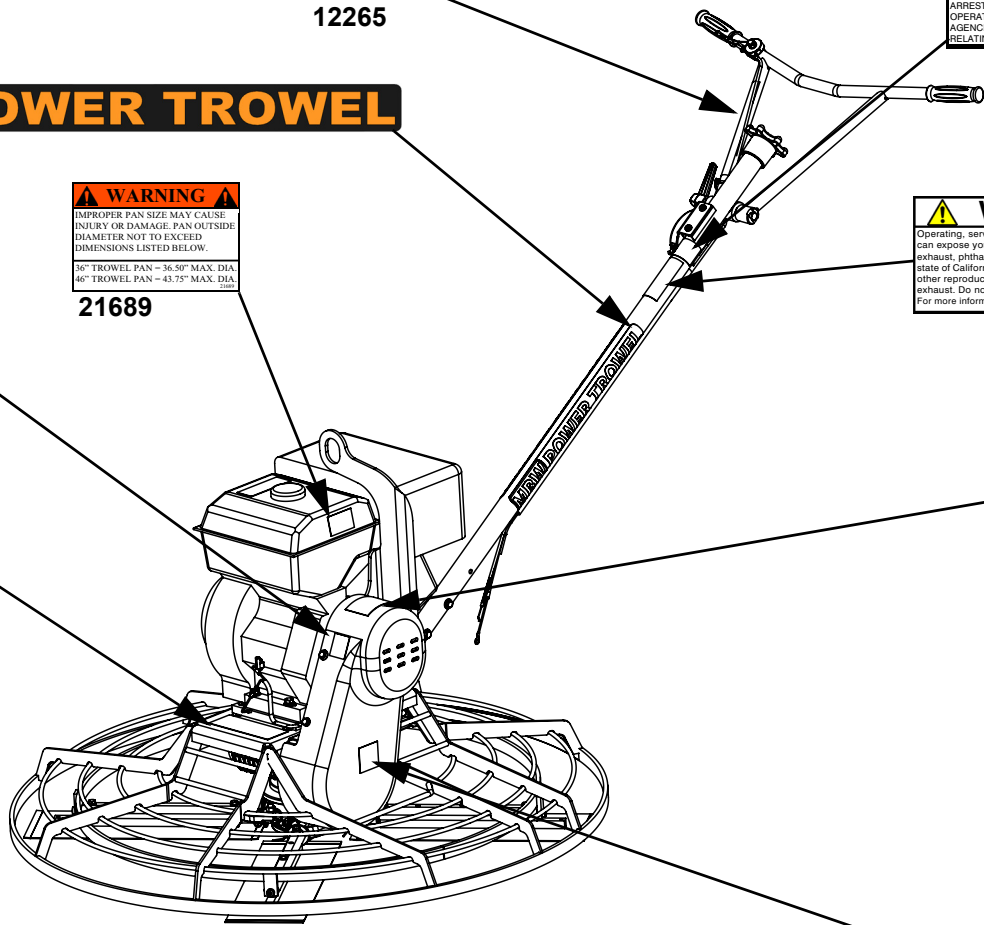

WARNING

**ROTATING PARTS
can crush and cut. Keep
hands away!**

19971



22222

OPERATING INSTRUCTIONS

1. Check engine oil and trowel gearbox oil.
2. Open fuel valve, put engine switch on.
3. Put **SAFETY SWITCH** in ON position; set throttle to idle position.
4. Choke engine. A warm engine may not need to be choked.
5. Starting engine: Place one hand on trowel handle and other hand on engine starter rope. NEVER place foot on guard ring. Pull starter rope.
6. Open choke, allow engine to warm up at idle.
7. Position throttle for various operating conditions.
8. TO STOP: Return throttle to idle position, put safety switch to off position. Choke fuel valve.

19970

WARNING

When lifting attach proper
safety chains to hook.
Approximate weight:
F46 Models:
260 lbs. (118 kg)
F36 Models:
209 lbs. (95 kg)

21188



WARNING
Correct
starting
position!

12267

MBW POWER TROWEL

21192

Safety Decal Sheet #19969

WARNING Start engine at idle only!
NEVER place foot on guard ring.

12265



22222



21799

WARNING
OPERATION OF THIS EQUIPMENT MAY
CREATE SPARKS THAT CAN START FIRES
AROUND DRY VEGETATION. A SPARK
ARRESTER MAY BE REQUIRED. THE
OPERATOR SHOULD CONTACT LOCAL FIRE
AGENCIES FOR LAWS OR REGULATIONS
RELATING TO FIRE PREVENTION.

19791

WARNING
Operating, servicing and maintaining this equipment
can expose you to chemicals, including engine
exhaust, phthalates and lead, which are known to the
state of California to cause cancer and birth defects or
other reproductive harm. Avoid breathing engine
exhaust. Do not operate equipment in confined areas.
For more information go to www.P65Warnings.ca.gov

21820

MBW POWER TROWEL

21192

WARNING Start engine at idle only!
NEVER place foot on guard ring.

12265



21186



22222

U.S. PATENT 10,053,873
P208 Trowel Handle

21628

WARNING
OPERATION OF THIS EQUIPMENT MAY
CREATE SPARKS THAT CAN START FIRES
AROUND DRY VEGETATION. A SPARK
ARRESTER MAY BE REQUIRED. THE
OPERATOR SHOULD CONTACT LOCAL FIRE
AGENCIES FOR LAWS OR REGULATIONS
RELATING TO FIRE PREVENTION.

19791

WARNING
Operating, servicing and maintaining this equipment
can expose you to chemicals, including engine
exhaust, phthalates and lead, which are known to the
state of California to cause cancer and birth defects or
other reproductive harm. Avoid breathing engine
exhaust. Do not operate equipment in confined areas.
For more information go to www.P65Warnings.ca.gov

21820

MBW POWER TROWEL

21192

Safety Decals - EZ Pitch/Low vibration Handle

SPECIFICATIONS

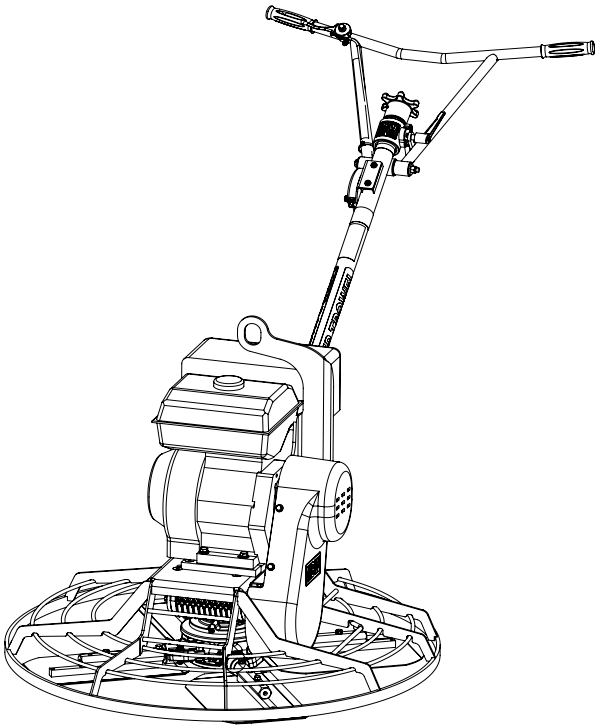

F36

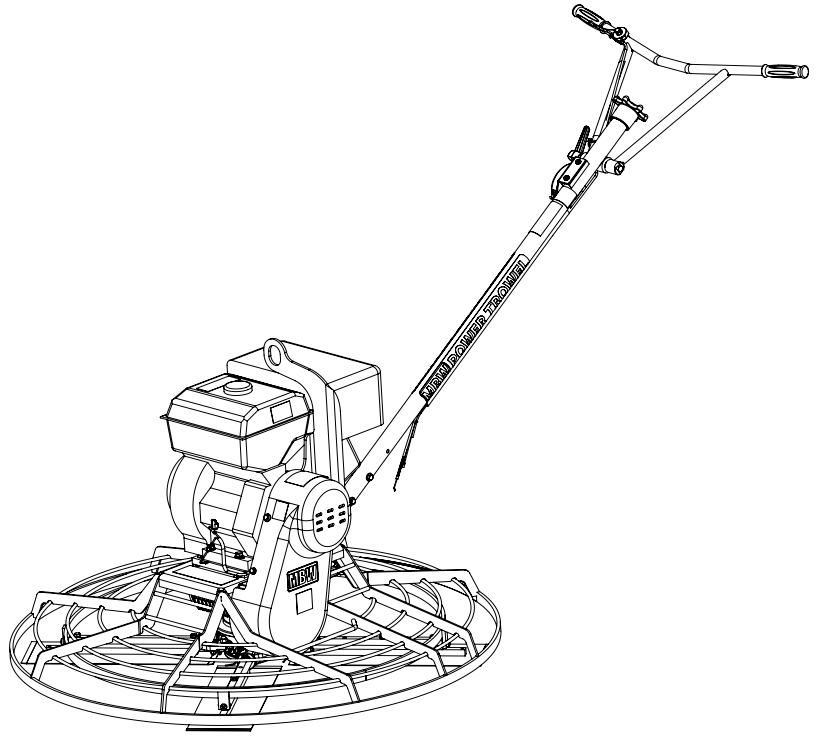

F46

	F36/4	F46/4
Ring Operating Diameter (Outside Diameter)	37-1/2 in. (95 cm)	46-5/8 in. (121 cm)
Blade Sweep Diameter	35.5 in. (90 cm)	46 in. (117 cm)
Max. Pan Diameter	36.5 in. (92.7 cm)	46.5 in. (118 cm)
Blade Pitch	0 To 20°	
Trowel Rotor Speed	35 - 180 rpm	
Low Vibration Handle Height (min./Max.)	35.8 - 43.3 in. (91-110 cm)	
Operating Overall Length	75 in. (191 cm)	83.6 in. (212 cm)
Gas Engines	GX270 Honda (16.5 in ³ /270cc)	GX390 Honda (23.7 in ³ /389cc)
Engine Speed	3600 rpm	
Operating Weight	Standard Handle: 216 lbs (98 kg) [GX270]	Standard Handle: 267 lbs (121 kg) [GX390]
Noise Level¹	85 - 105 dBA	

Specifications subject to change without notice

1. Noise levels are based on operating conditions and will vary with background noise

OPERATION

Introduction

MBW equipment is intended for use in very severe applications. They are powered by four cycle engines and are available in different sizes and a selection of engines.

This parts manual contains only standard parts. Variations of these parts as well as other special parts are not included. Contact your local MBW distributor for assistance in identifying parts not included in this manual.

Before Starting & Operating

- **REMEMBER!** It is the owner's responsibility to communicate information on the safe use and proper operation of this unit to the operators.
- Review ALL of the Safety Precautions listed on page 1 of this manual.
- Familiarize yourself with the operation of the machine and confirm that all controls function properly.
- Know how to STOP the machine in case of an emergency.
- Make sure hands, feet, and clothing are at a safe distance from any moving parts.
- **NEW TROWELS** - After assembling the handle, inspect the throttle connections and confirm the remote throttle is actuating the engine throttle properly and all controls function properly.
- **FUEL SUPPLY** - The engines on MBW Power Trowels require a good grade of unleaded automotive gasoline. See the engine owner's manual for specific details. Engines are NOT approved to run E85 fuel.
- **ENGINE OIL** - Check the oil level in the engine. Refer to the Lubrication section of the engine owner's manual.
- **GEARBOX OIL** - Check the oil level in the trowel gearbox. Refer to the Maintenance section of this manual.
- **AIR CLEANER** - Check to make sure the element is in good condition and properly installed. Clean or replace filter element if clogged or damaged.

Starting Engine

1. Open fuel valve.
2. Turn engine switch to "ON".
3. Turn trowel safety switch to "ON".
4. Set throttle to idle.

5. Choke engine if necessary (you may not need to choke a warm engine).
6. Place one hand on the trowel handle and the other on the starter rope. Pull starter rope repeatedly until engine starts.



WARNING



NEVER place foot inside the guard ring when starting.

7. Move choke lever to open position and allow engine to warm up for one or two minutes.

Operating

1. Increase throttle to engage the clutch.
2. Set throttle to desired position to achieve the appropriate trowel blade speed.
3. To move forward, push down on the right handle grip and pull up on the left handle grip.
4. To move backward, pull up on the right handle grip and push down on the left handle grip.
5. To move left, pull up on both handle grips.
6. To move right, push down on both handle grips.

Blade Pitch Adjustment (Standard)

1. To increase the pitch, rotate the tilt knob clockwise.
2. To decrease the pitch, rotate the tilt knob counterclockwise.

Blade Pitch Adjustment (Power Pitch)

1. To increase pitch, push toggle up.
2. To decrease pitch, push toggle down.

Blade Pitch Adjustment (EZ Pitch)

1. To increase the pitch, squeeze the trigger and pull the lever towards you.
2. To decrease the pitch, squeeze the trigger and push the lever away from you.

Handle Height Adjustment (Low Vibration)

Refer to handle assembly pages:

1. Rotate handle height adjustment lever (16) counter clockwise to loosen. If lever is tight to handle bar, pull out on lever and rotate away from handle bar and release lever.

2. Move handle bar to desired height.
3. Rotate handle height adjustment lever (16) clockwise to re-tighten.
4. If lever (21) is not parallel to handle bar when tight, pull out on lever and rotate lever and release lever when up against handle bar.

(Standard & EZ Pitch Handle)

1. Loosen handle height adjustment lever. If lever is tight to handle bar, pull out on lever and rotate away from handle bar and release lever.
2. Move handle bar to desired height.
3. Retighten handle height adjustment lever.

Stopping Engine

1. Move throttle to idle position.
2. Turn trowel safety switch to "OFF".
3. Close the fuel valve.



WARNING



Always stop the engine before:

Adding fuel.

Leaving the equipment unattended for any amount of time.

Before making any repairs or adjustments to the machine.

MAINTENANCE



WARNING



Always exercise the stopping procedure before servicing or lubricating the unit.

After servicing the unit, replace and fasten all guards, shields, and covers to their original positions before resuming operation.



CAUTION



Always verify fluid levels and check for leaks after changing fluids.

Do not drain oil onto ground, into open streams, or down sewage drains.

Maintenance Schedule

MAINTENANCE	10 HOURS OR DAILY	50 HOURS OR WEEKLY	100 HOURS OR MONTHLY	500 HOURS OR YEARLY
Grease yoke plate	X			
Grease spider	X			
Change gearbox oil				X
Check gearbox oil	X			
Inspect drive belt		X		
Lubricate Drive Clutch Bushing		X		
Check and tighten all hardware ¹			X	

1. Check all hardware after the first 5 hours of use, then follow the maintenance schedule.

Fluid Levels

SYSTEM	FLUID VOLUME	RECOMMENDED OIL
Gearbox Oil	21 oz. (620 ml)	#680 140wt Sulfur Free (MBW #05700)
Engine	Refer to engine operator/owner manual	

Engine Maintenance

Refer to the engine owner's manual for maintenance intervals and procedures.

Engine Oil

Refer to the engine owner's manual for recommended oil change intervals.



WARNING



Never change the oil when engine is hot. Allow engine to cool before maintaining.

To drain the oil, lift and tip the trowel forward onto the guard ring using the trowel handle. Place a drain pan underneath the engine and remove the drain plug. After the oil has finished draining, reinstall the plug and clean any spilled oil from the trowel.

Engine Speed

The engine speed is factory preset according to the Specifications section. Do not tamper with the governor settings. The governor establishes safe operating limits. These limits must not be exceeded.

Cleaning

Always clean the trowel thoroughly after each day's operation. Dried concrete buildup can hinder performance and shorten the life of the trowel.

Lubrication

- Grease the yoke plate and spider (see Spider Assembly, page 16) every 10 hours or daily with a lithium base, low temperature, general purpose lube.

2. Lightly lubricate drive clutch bushings with silicone spray 50 hours or if handle starts to rotate at idle. Wipe off any excess lubricant to avoid belt slipping.

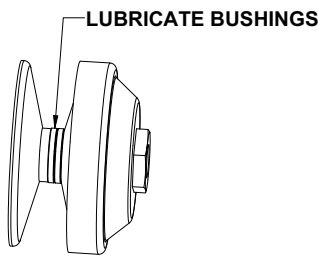

3. Change the gearbox oil once every season or 500 hours, whichever comes first. The drain/fill plug is located on the right-hand side of the gearbox. Fill it with 21 oz. (620 ml) of MBW Worm Gear Oil (MBW #05700). The oil should be to the bottom of the fill hole when sitting level.

Lifting

The trowel should be lifted by the lifting bracket attached to the engine. As an alternative, it may be lifted by two people on opposite sides of the guard ring.

Storage

The trowel should be stored with blocks supporting the outer guard ring. Refer to the engine owner's manual for information regarding storage of the engine.

Setting Safety Switch

Refer to Standard Handle Assembly, page 24.

1. Remove screws (12) & lock washers (20) securing safety switch assembly to handle tube (19).
2. Remove inside cover and set screw to dimension shown in figure 7, in the Service Section of this manual.

Changing Trowel Blades



WARNING



Trowel blade edges may be sharp when they are worn. Wear protective gloves when handling the blades.

1. Set the trowel on a level surface.
2. Remove the bolts securing the blade to the tilt arm.
3. Lift up on the ring guard and slide the blade out from under the tilt arm.
4. Slide the new blade under the tilt arm.
5. Reinstall the bolts and tighten.

6. Check that the carriage bolts are set properly. If they require adjustment refer to the "Setting Tilt Arm Carriage Bolt Height" section.

Setting Tilt Arm Carriage Bolt Height

1. Remove **ALL** the tilt arms from the spider.
2. Remove the blades from all the arms. Wear protective gloves when removing the blades, the edges may be sharp
3. Inspect the bottom side of the arms (blade mounting surface). Remove any nicks, cement, etc... **THIS SURFACE MUST BE FLAT**
4. Loosen the jam nut and run the carriage bolt in as far as possible.
5. Mount the arm to gage #07277 as shown in figure 1.

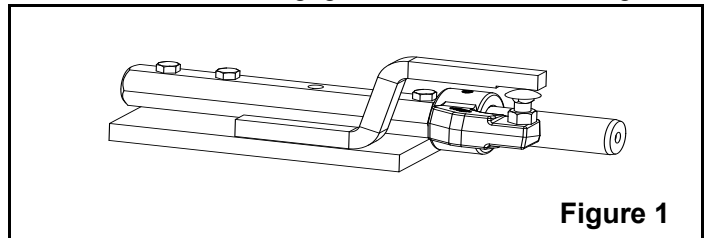

Figure 1

6. Place a .030 feeler gage between the carriage bolt and the underside of the gage arm, and run the carriage bolt up to just contacting the feeler gage. There should be a slight drag felt when the feeler gage is moved between the two surfaces.
7. Place a 3/8" open end wrench on the square shoulder of the carriage bolt and tighten the jam nut. **DO NOT** allow the carriage bolt to turn.
8. Recheck clearance with feeler gage and readjust if necessary.
9. Repeat items 5 through 8 for **ALL** remaining tilt arms.
10. Lubricate the tilt arm prior to fitting it in spider.

Replacing Power Pitch Fuse

Refer to Power Pitch Switch & Battery, page 32.

Trowels equipped with the MBW Power Pitch handle system use a fuse located in the battery compartment to protect the system.

1. Open battery compartment cover (5) and remove battery, if present.
2. Locate fuse holder (7) on battery mount plate (15).
3. Using a flat bladed screwdriver, turn center portion of fuse holder 1/8 turn counter clockwise until it pops out.
4. Replace fuse with "2AG" type, 4 amp.

Adjusting Power Pitch Actuator

Refer to Power Pitch Actuator & Wiring, page 30.

Trowels equipped with the MBW Power Pitch handle system may periodically need adjustment to achieve full range of blade pitch angle.

1. Place trowel on a flat surface and extend actuator fully.
2. Loosen, but do not remove, clamping nut (12) from upper actuator mount (7).
3. Slide upper actuator mount rear and upward in slot of support bracket (5) until resistance is met, Then tighten bolt (14) in end of bracket to hold in place.
4. Tighten clamping nut (12).
5. Run actuator through entire stroke to ensure proper operation.

SERVICE

Assembly and disassembly should be performed by a service technician who has been factory trained on MBW equipment. The unit should be clean and free of debris. Pressure washing before disassembly is recommended.

- Prior to assembly, wash all parts in a suitable cleaner or solvent.
- Check moving parts for wear and failure. Refer to the Replacement section in this manual for tolerance and replacement cycles.
- All shafts and housings should be oiled prior to pressing bearings. Also, ensure that the bearings are pressed square and are seated properly.
- All bearings, seals, o-rings and gaskets should be replaced when rebuilding gearbox.

Torque Chart

SIZE	GRADE 2	GRADE 5	GRADE 8
1/4-20	49 in•lbs	76 in•lbs	9 ft•lbs
1/4-28	56 in•lbs	87 in•lbs	10 ft•lbs
5/16-18	8 ft•lbs	13 ft•lbs	18 ft•lbs
5/16-24	9 ft•lbs	14 ft•lbs	20 ft•lbs
3/8-16	15 ft•lbs	23 ft•lbs	33 ft•lbs
3/8-24	17 ft•lbs	26 ft•lbs	37 ft•lbs
7/16-14	24 ft•lbs	37 ft•lbs	52 ft•lbs
7/16-20	27 ft•lbs	41 ft•lbs	58 ft•lbs
1/2-13	37 ft•lbs	57 ft•lbs	80 ft•lbs
1/2-20	41 ft•lbs	64 ft•lbs	90 ft•lbs
9/16-12	53 ft•lbs	82 ft•lbs	115 ft•lbs
5/8-11	73 ft•lbs	112 ft•lbs	159 ft•lbs
5/8-18	83 ft•lbs	112 ft•lbs	180 ft•lbs
3/4-16	144 ft•lbs	200 ft•lbs	315 ft•lbs
1-8	188 ft•lbs	483 ft•lbs	682 ft•lbs
1-14	210 ft•lbs	541 ft•lbs	764 ft•lbs
1-1/2-6	652 ft•lbs	1462 ft•lbs	2371 ft•lbs
M 6	3 ft•lbs	4 ft•lbs	7 ft•lbs
M 8	6 ft•lbs	10 ft•lbs	18 ft•lbs
M 10	10 ft•lbs	20 ft•lbs	30 ft•lbs

CONVERSIONS

in•lbs x 0.083 = ft•lbs

ft•lbs x 12 = in•lbs

ft•lbs x 0.1383 = kg•m

ft•lbs x 1.3558 = N•m

Service Tools

Part No.	Description
07276	Adjustment Tool, Tilt Arm Parallelism
07277	Adjustment Tool, Tilt Arm Height Gage
07279	Installation Tool, Spider Bushing (#06459)
16421	Bearing Spool Tool (Constant Force)
20860	Clutch Drive Tool

Gearbox Disassembly

Refer to Gearbox Assembly, page 16.

1. Remove handle see handle remove section, belt guard & drive assembly (page 20), guard ring (page 22).
2. Loosen square head set screw (page 16, #18) until gearbox can be lifted off the spider assembly.
3. Flip gearbox (8) over and set it on guard ring pads.
4. Remove yoke arm (11) by removing one retaining rings (7), securing pivot rod (14) and slide rod out of hole.
5. Remove bolts (30) and flat head screws (31) that hold cover (9) to the gearbox housing (8).
6. Remove cover and discard shims (13) and o-ring (6).
7. Remove retaining ring (23) and seal (1) from cover, discard seal.
8. Pull out shaft (18) with bearings (3) and worm gear (17) and drain oil out of gearbox.
9. Press bearing (#3) and worm gear (17) off long side of shaft (18).
10. Remove key (19) and retaining ring (2) from shaft.
11. Press remaining bearing (#3) off of shaft.
12. Remove bolts (29) and bearing cap (20). Discard shim gasket (12) and o-ring (24).
13. Remove worm shaft (15) and bearings (4).
14. Remove retaining cap (10), discard shim gasket (12) and o-ring (24).

Gearbox Assembly

Refer to Gearbox Assembly, page 16.

1. Lightly oil shaft (18). Install key (19) and retaining ring (2) onto shaft.
2. With retaining ring end of shaft down, press worm gear (17) onto shaft. Make sure the longer hub of worm gear is down. Worm gear should be pressed on

- shaft until the recess in the worm gear hub is snug against the retaining ring.
3. Press bearings (3) on each end of shaft. Make sure bearings are butted against worm gear shoulders.
 4. If bearing races are replaced make sure new races are properly seated.
 5. Set worm gear and shaft assembly into gearbox housing. Assemble cover (9) and one.010" shim #05401 (13) into place.
 6. Apply down pressure to cover and check shaft for end play, no end play & no pre-load.
 7. Remove cover and install the proper shims (13) for no end play.
 8. Brush a light coat of oil on o-ring groove and inside lip of cover. Roll o-ring (6) over the inside lip and into groove in the cover.
 9. Install seal (1) into cover from outside to inside edge of retaining ring groove. Be sure it is installed square and flat.
 10. Install retaining ring (23) into cover.
 11. Use a piece of thin plastic over shaft to protect seal and install cover into gearbox housing. Secure with two flange bolts (30) and two flat head screws (31).
 12. Rotate shaft, there should be a little drag. If there is too much drag another shim should be added until a slight seal drag is felt. If there is side play in the shaft a shim must be removed.
 13. Measure main shaft run out. Maximum acceptable total indicator run out is .0035 inches.
 14. Apply pipe sealant to threads and Install drain plug (32) and relief valve (22) if removed.
 15. Brush a light coat of oil on o-ring (24) & roll over inside lip and into groove of retaining cap (10).
 16. Install two .010" shims #05360 (12) with retaining cap on drain plug side of gearbox with four flange bolts (29). Torque bolts to 90 in/lbs in an "X" pattern.
 17. Press bearings (4) on each end of worm shaft (15). Make sure bearings are butted against worm shaft shoulders.
 18. Install the worm shaft (15) with bearings (4) into gearbox housing. Gears must be meshed properly.
 19. Install bearing cap (20) and apply pressure towards gearbox (8). Rotate worm shaft and check for end play and gear backlash.
 20. Remove bearing cap and install proper shims (12) for no back lash & no end play.
 21. Install new seal (21) into bearing cap (20) from outside. Make sure the seal is installed square & flat.
 22. Brush a light coat of oil on o-ring groove, roll o-ring (24) over inside lip and into groove of bearing cap.

23. Pour one can (21 oz.) of #05700 oil into worm shaft opening. Install cap and secure with four flange bolts (29). Torque bolts to 90 in/lbs in an "X" pattern.
24. Apply a small amount of loctite #290 to inside of spacer (16) and push onto the worm shaft (15) through oil seal (21) and up against bearing (4) inside of the gearbox housing.

Handle Removal/Installation

Refer to Standard Handle Assembly, page 24.

1. Remove bottom lock nut (27) from pitch cable (6).
2. Slide pitch cable end out of pivot pin (7) and remove jam nut (28) from pitch cable (6).
3. Disconnect shorting wires (9) from engine.
4. Disassemble throttle wire from engine.
5. Remove screws (26), washers (24) and lock nuts (27) from handle tube (18) and slide handle off of gear box tube. **For F36 only**, remove top screw only (26), washers (24) & lock nut (27) in gear box tube, loosen only the lower screw (26).
6. Slide the handle assembly off the handle mounting tube.
7. To re-assemble the handle, slide the handle assembly on to the handle mounting tube, guiding pitch cable end thru cable slide, F46 only.
8. Install screws (26), washers (24) and lock nuts (27). **For F36 only**, install top screw (26), washers (24) & lock nut (27) in gear box tube, tighten lower screw loosened in step #5.
9. Assemble hex jam nut (28) to pitch cable (6)
10. Slide the threaded end of the pitch cable (6) into the pivot pin (7) and assemble lock nut (27) to cable (6).
11. Route safety switch wire between engine and belt guard and reconnect to engine.
12. Install throttle wire to engine.

Gas Spring Replacement

Refer to EZ Pitch Handle Assembly, page 28.



1. Move the EZ pitch handle to the most extend, pitched, position to take pressure of the gas spring, see figure #2.
2. See the "Handle Removal" section of the manual to remove the handle from the trowel.

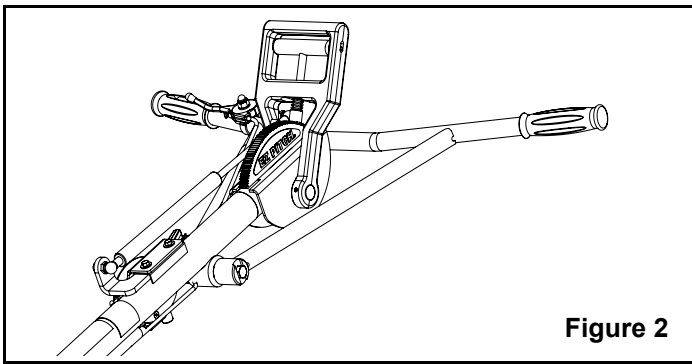

3. Remove flange lock nut (34) securing gas spring (18) to bracket (14).
4. Remove button head screw (30) and washer (6) from tube (22) just below gear assembly (15).
5. Slide EZ pitch assembly out of top of tube (22).
6. Unhook EZ pitch lever (19) from pitch cable links (16).
7. Remove three spiral pins (29) from activating shaft (11), handle (9) and EZ pitch lever (19).
8. Slide activating shaft (11) out of gear assembly (15) and remove handle assembly (9).
9. Remove gas spring (18) from handle assembly (9) and replace with new gas spring.
10. Slide activating shaft (11) thru handle (9), gear assembly (15) and EZ pitch lever (19) and reinstall spiral pins (29). Note position of EZ pitch lever (19).
11. Lock handle assembly (9) in extended position as shown in figure #2.
12. Slide pitch cable links (16) into gear assembly (15) over top of activating shaft (11) and hook into EZ pitch lever (19).
13. Slide EZ pitch assembly into top of handle tube (22), guiding cable into top of cable slide (13) F36 handle only, see figure #3.
14. Align hole in gear assembly (15) with hole in top of handle tube (22) and install washer (6) and button head screw (30) with blue loctite.
15. Assemble bottom end of gas spring (18) to mounting bracket (14) with lock nut (34).
16. Reinstall handle assembly to trowel per the "Handle Removal/installation" section of this manual.

Low Vibration handle Cable Replacement

Refer to Low Vibration Handle Assembly, page 26.

1. See the "Handle Removal" section of the manual to remove the handle from the trowel.
2. Remove screws (11), washers (27) and remove safety switch assembly (#24).
3. Turn pitch control knob all the way counterclockwise.
4. Remove button head screw (28) and washer (10) from tube below pitch control knob (3).

5. Remove socket head screw (31) from slot on right side of handle tube (21).
6. Slide pitch cable assembly out top of tube, guiding threaded end thru cable slide on bottom end of tube.
7. Remove button head screw (30) from shaft adapter (22) to remove cable (6).
8. Assemble new cable (6) to shaft adapter (22), with screw (30), note cable position for F36 or F46 handle
9. Slide pitch cable assembly into top of handle tube

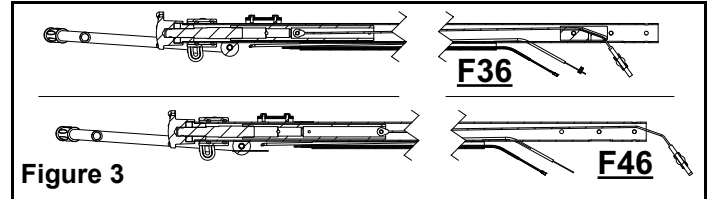

(21), guiding cable into top of cable slide (23), F36 handle, see figure #3.

10. Install socket head screw (31) to shaft adapter (22) thru slot on right side of handle tube (21).
11. Align hole in bearing (4) with hole in top of handle tube (21) and install button head screw (28) and washer (10).
12. Slide handle assemble on handle mounting tube on gear box & reinstall hardware removed in the "Handle Removal" section of this manual.

Shorting Wire Replacement

Refer to Standard Handle Assembly, page 24.

1. Assemble shorting wire (#9) to both screws on safety switch (15). Reset screw height as shown in figure #7.
2. Remove short wire with ring terminal from end of harness (9). Rout harness inside small tube on handle (18) & between engine and belt guard as shown in figure 8.
3. Connect bullet terminal to engine shut-off switch wire. Reattach short wire & assemble ring terminal to lower right engine shroud screw, as shown in figure #8.

High Speed Clutch Spring Replacement

Refer to Drive Assembly, page 20.

1. Remove clutch assembly from trowel.
2. Place service tool #20860 inside drive clutch and secure in bench vise.

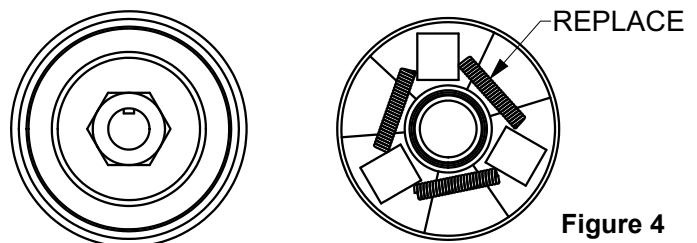

Figure 4

3. Slowly loosen clutch cover, counter clockwise and remove (Warning: Cover under light spring tension)
4. Locate springs under cover and replace with spring kit (MBW #20859).
5. Reassemble clutch and mount to trowel.

Spider Bushing Removal

Refer to Figure #5

1. Screw 3/4-14 pipe tap half way into outer bushing.
2. Insert push rod into opposite side of spider.
3. Use a tube on upper end to press old bushings out.
4. Repeat with inner bushings.

Power Pitch Actuator Replacement

Refer to Power Pitch Actuator & Wiring, page 30.

1. If possible, extend actuator. If unable, elevate trowel off blades and support from guard ring to relieve pressure on blade tilt mechanism.

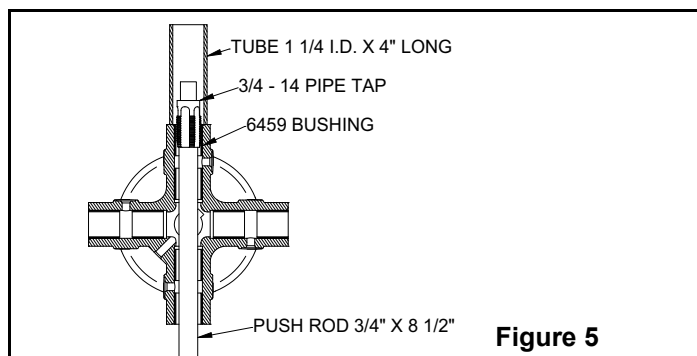

Figure 5

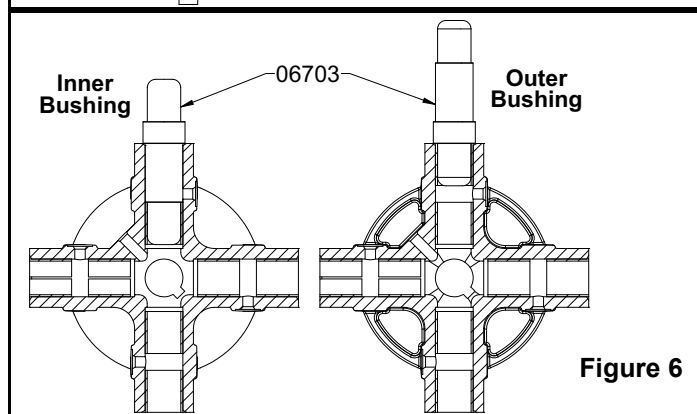

Figure 6

2. Disconnect wiring to actuator.
3. Remove machine screw (13) securing pin (3) at top of actuator. Use screw to remove pull-pin.
4. Remove machine screw (13) at bottom of actuator and pull-pin (3).
5. Swivel lower end of actuator away from mount, then pull down and out from guard (6).
6. Plug in new actuator wiring and extend fully.
7. Insert rod (upper) end of actuator into guard, then lower end of actuator into socket in the lower actuator mount(4). Align lower holes and insert pull-pin to secure.
8. Secure lower pull pin with washer (9) and screw (13).
9. Align holes in upper end of actuator and top mounting bracket (7). If needed, elevate trowel and pitch blades manually. Insert pull-pin (3) and secure with washer (9) and screw (13).
10. Refer to maintenance section of this manual to adjust actuator for maximum pitch.

Spider Bushing Replacement

Refer to Figure #6 for bushing installation:

1. Install inner bushings into spider with long side of installation tool #60703 to ensure proper depth.
2. Using the opposite end or short end of installation tool #06703, install (4) outer bushings into spider.

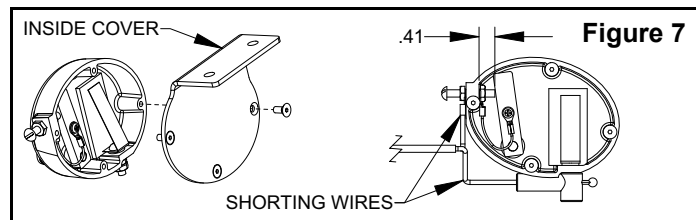

Figure 7

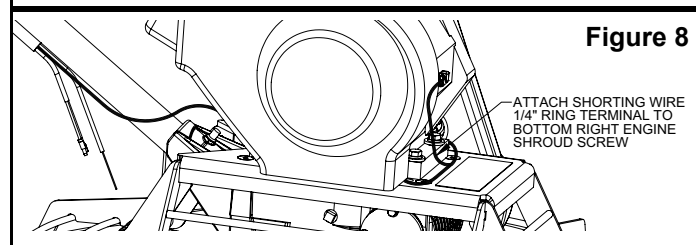

Figure 8

Parts Replacement Cycles and Tolerances

Air Cleaner Element	Replace after 100 hours if the engine is operating under good clean air conditions. Service and replace more frequently if under more severe conditions.
Bearings	Replace anytime bearing is rough, binding, discolored or removed from housing or shaft.
Blades	Replace when the edges become sharp or uneven. (Finish blades can be reversed)

Bushings, Trowel Arm	Replace if the trowel arm can be moved up and down more than 3/4 inch (19 mm) at the end of the arm.
Carriage Bolts	Reset the height after trowel arm teardown or if the trowel develops chatter or windmilling. Use height gage kit #07277 when setting.
Clutch	Lubricate clutch bushings if it does not disengage below 2000 rpm. See the lubrication portion of the Maintenance section.
Gaskets and Seals	Replace at every overhaul and teardown. Use MBW gasket and seal kit #05470.
Gearbox Oil	Replace after the first 50 hours of operation, then every 500 operating hours or yearly.
Spark Plug	Change after 75 hours of operation.
Torque Bolts	Re-torque all the bolts after first eight hours of operation and check every 25 hours.
Worm Gear	Replace if the teeth show wear marks or become sharp.
Worm Shaft	Replace if the teeth show wear marks or become sharp.

REPLACEMENT PARTS

The warranty is stated in this book on page 34. Failure to return the Warranty Registration Card renders the warranty null and void.

MBW, Inc. has established a network of reputable distributors with trained mechanics and full facilities for maintenance and rebuilding, and to carry an adequate parts stock in all areas of the country. Their sales engineers are available for professional consultation. If you cannot locate an M-B-W distributor in your area, contact MBW, Inc. or one of our Sales Branches listed below.

When ordering replacement parts, be sure to have the following information available:

- Model and Serial Number of machine when ordering M-B-W parts
- Model and Serial Number of engine when ordering engine parts
- Part Number, Description, and Quantity
- Company Name, Address, Zip Code, and Purchase Order Number
- Preferred method of shipping

REMEMBER - You own the best! If repairs are needed, use only M-B-W parts purchased from authorized M-B-W distributors.

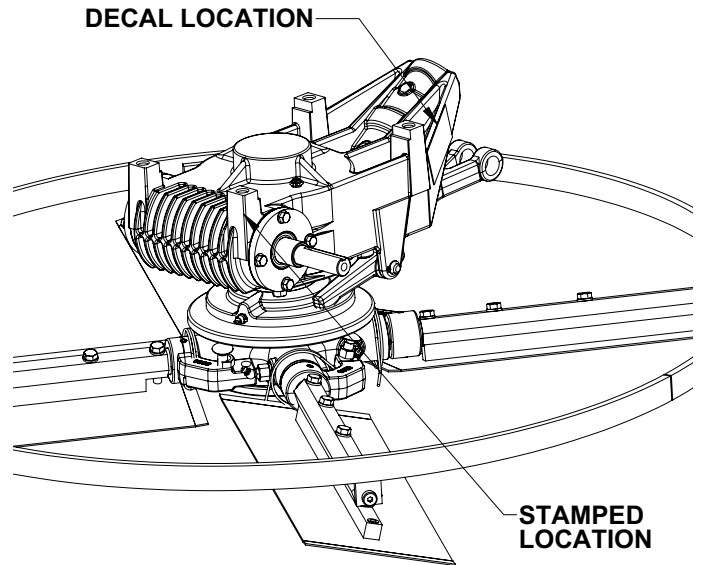

The unit's serial number can be found in the following locations:

- The model/serial number decal is located on the rear side of the gearbox, next to the engine and belt guard.
- The serial number is stamped on the front of the gearbox.

Write Model Number here

Write Serial Number here

Contact Information

MBW, Inc.

250 Hartford Rd • PO Box 440
Slinger, WI 53086-0440
Phone: (262) 644-5234
Fax: (262) 644-5169
Email: mbw@mbw.com
Website: www.mbw.com

MBW Europe Ltd.

Units 2&3 Cochrane Street
Bolton BL3 6BN
England, UK
Phone: +44 (0) 1204 387784
Fax: +44 (0) 1204 387797
Email: saleseurope@mbw.com
Website: mbw-europe.com

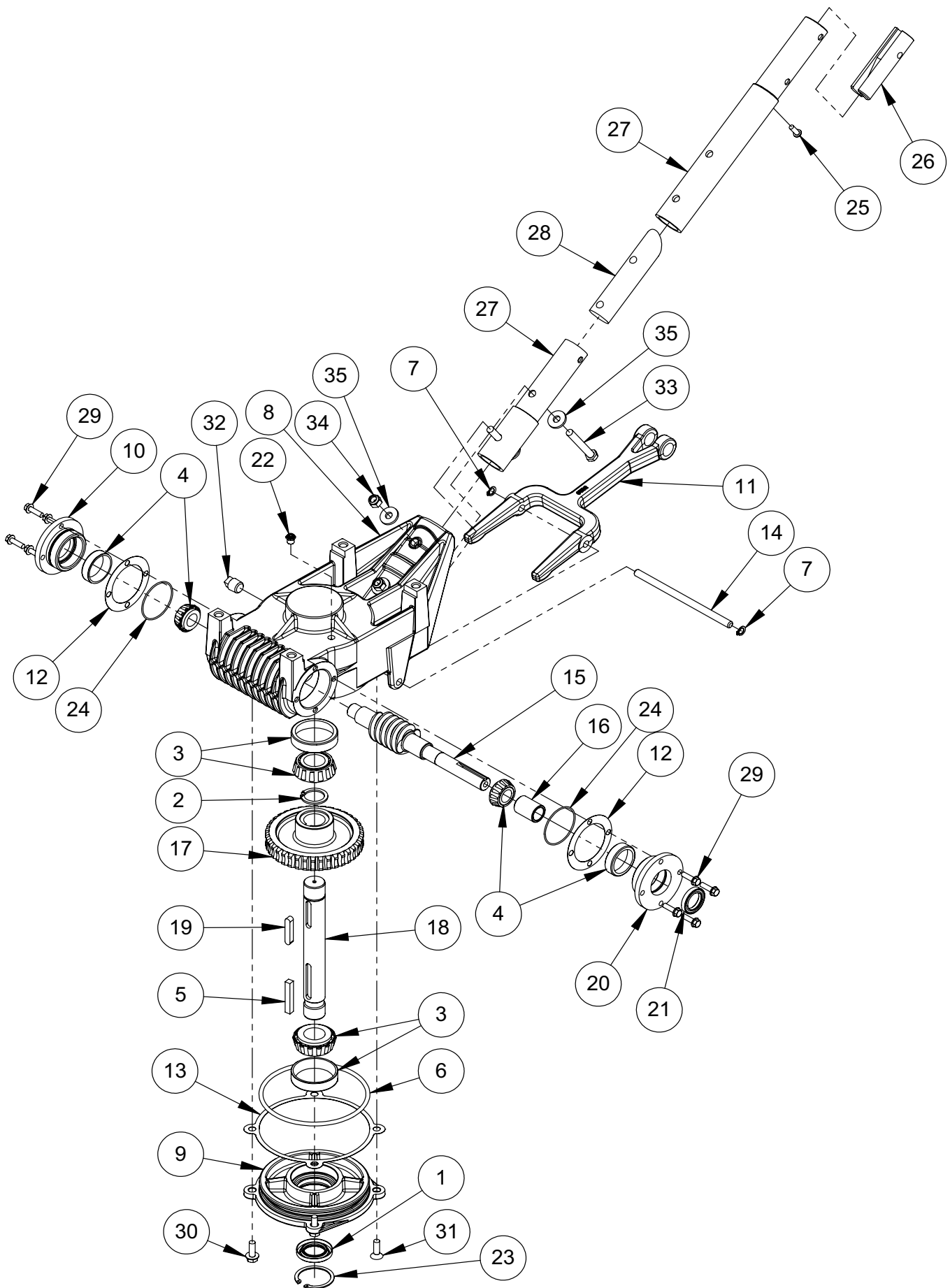

Gearbox Assembly

ITEM	PART NO.	DESCRIPTION	F36	F46
1.	01243	SEAL, GEAR SHAFT	1	1
2.	01244	RETAINING RING, EXTERNAL	1	1
3.	01251	BEARING TAPER ROLLER (Includes Bearing & Cup)	2	2
4.	01252	BEARING TAPER ROLLER (Includes Bearing & Cup)	2	2
5.	01254	KEY, 5/16 SQUARE x 2 lg.	1	1
6.	01256	O-RING	1	1
7.	01279	RETAINING RING, EXTERNAL	2	2
8.	05323	HOUSING, GEARBOX	1	1
9.	05326	COVER, GEARBOX	1	1
10.	05327	CAP, BEARING	1	1
11.	05329	ARM, YOKE	1	1
12.	05359	SHIM GASKET, 0.004"		
	05360	SHIM GASKET, 0.010"		
13.	05361	SHIM GASKET, 0.004"		
	05401	SHIM GASKET, 0.010"		
14.	05396	ROD, PIVOT	1	1
15.	05515	WORM SHAFT	1	1
16.	05518	SPACER	1	1
17.	05521	GEAR, WORM	1	1
18.	05523	SHAFT, OUTPUT	1	1
19.	05524	KEY, 5/16" SQUARE x 1-11/16" LONG	1	1
20.	05532	CAP, BEARING	1	1
21.	05533	SEAL, INPUT SHAFT	1	1
22.	06037	VALVE, RELIEF	1	1
23.	06264	RETAINING RING	1	1
24.	06392	O-RING	2	2
25.	21009	HI-LOW SCREW, 1/4 X 3/4, TORX		1
26.	21585	CABLE SLIDE, TROWEL HANDLE		1
27.	21586	TUBE MOUNT, F36	1	
	21588	TUBE MOUNT, F46		1
28.	21590	HANDLE SPACER, F46		1
29.	F042007FWS	FLANGE BOLT, 1/4-20 x 7/8"	8	8
30.	F051807FWS	FLANGE BOLT, 5/16-18 x 7/8"	2	2
31.	F051808FSS	FLAT HEAD SCREW, 5/16-18 x 1"	2	2
32.	F0618SHPP	PIPE PLUG, 3/8"	1	1
33.	F061622HCS	HEX HEAD CAP SCREW, 3/8-16 X 2-3/4 LG., GR8	2	2
34.	F0616ELN	LOCK NUT, 3/8-16, NYLOC, ZP	2	2
35.	F06SW	FLAT WASHER, 3/8 ZP.	4	4
		REPLACEMENT KITS		
	05470	KIT, GASKET & SEAL (includes 1, 12, 13, 21 & 23)		
	05546	GEARBOX ASSEMBLY (includes all above items)		
	05700	GEAR OIL, CHEVRON #680		

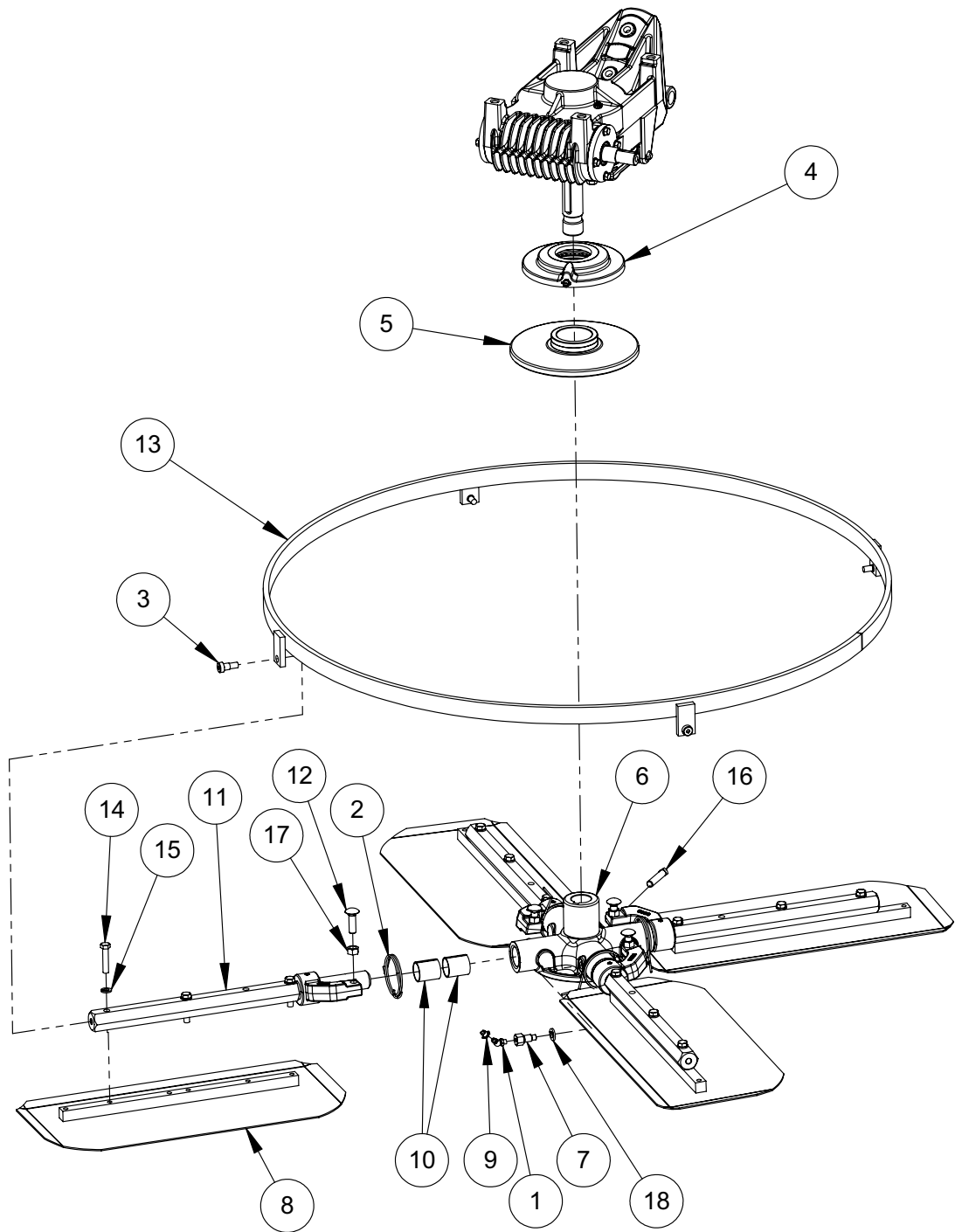

Spider Assembly

ITEM	PART NO.	DESCRIPTION	F36/4	F46/4
1.	01169	GREASE FITTING, 45	4	4
2.	01258	SPRING	4	4
3.	01280	SOCKET HEAD SHOULDER SCREW, 3/8" x 3/8"		4
4.	22731	YOKE PLATE ASM.	1	1
5.	05330	PRESSURE PLATE, 4-ARM*	1	1
6.	05331	SPIDER, 4-ARM (includes 15)*	1	1
7.	05397	BOLT, HOLLOW	4	4
8.	05402	COMBINATION BLADE, 8" x 14"	4	
	05412	COMBINATION BLADE, 8" x 18"		4
9.	05492	CAP, GREASE	4	4
10.	06459	BUSHING, SPLIT	8	8
11.	06755	TILT ARM, 36" (includes 15 & 20)	4	
	07850	TILT ARM, 46" (includes 15 & 20) Serial number 1470019 & lower and 1470130 & up.		4
	21368	TILTARM, 46, (includes items 15 & 20) Serial number 1470020 thru 1470129.		4
12.	17190	CARRIAGE BOLT, (SPECIAL) 3/8-16 x 1-1/4" LG.	4	4
13.	21230	STABILIZER RING		1
14.	F051812HC	HEX HEAD CAP SCREW, 5/16-18 x 1-1/2"	8	16
15.	F05LW	LOCKWASHER, 5/16"	8	16
16.	F061614SH	SQUARE HEAD SET SCREW, 3/8-16 x 1-3/4"	1	1
17.	F0616HN	HEX NUT, 3/8-16	4	4
18.	F06LW	LOCKWASHER, 3/8"	4	4
		REPLACEMENT KITS		
	01427	GREASE FITTING CAPS (sold in sets of 12)		5
	06199	Kit, Spider (include 1, 2, 6, 7, 9, 11, 12, 16, 17 & 18)	1	
	07898	Kit, Spider (includes 1, 2, 6, 7, 9, 11, 12, 16, 17 & 18) Serial #1470019 & lower and #1470130 & up.		1
	21369	Kit, Spider (includes 1, 2, 6, 7, 9, 11, 12, 16, 17 & 18) Serial #1470020 thru #1470129.		1

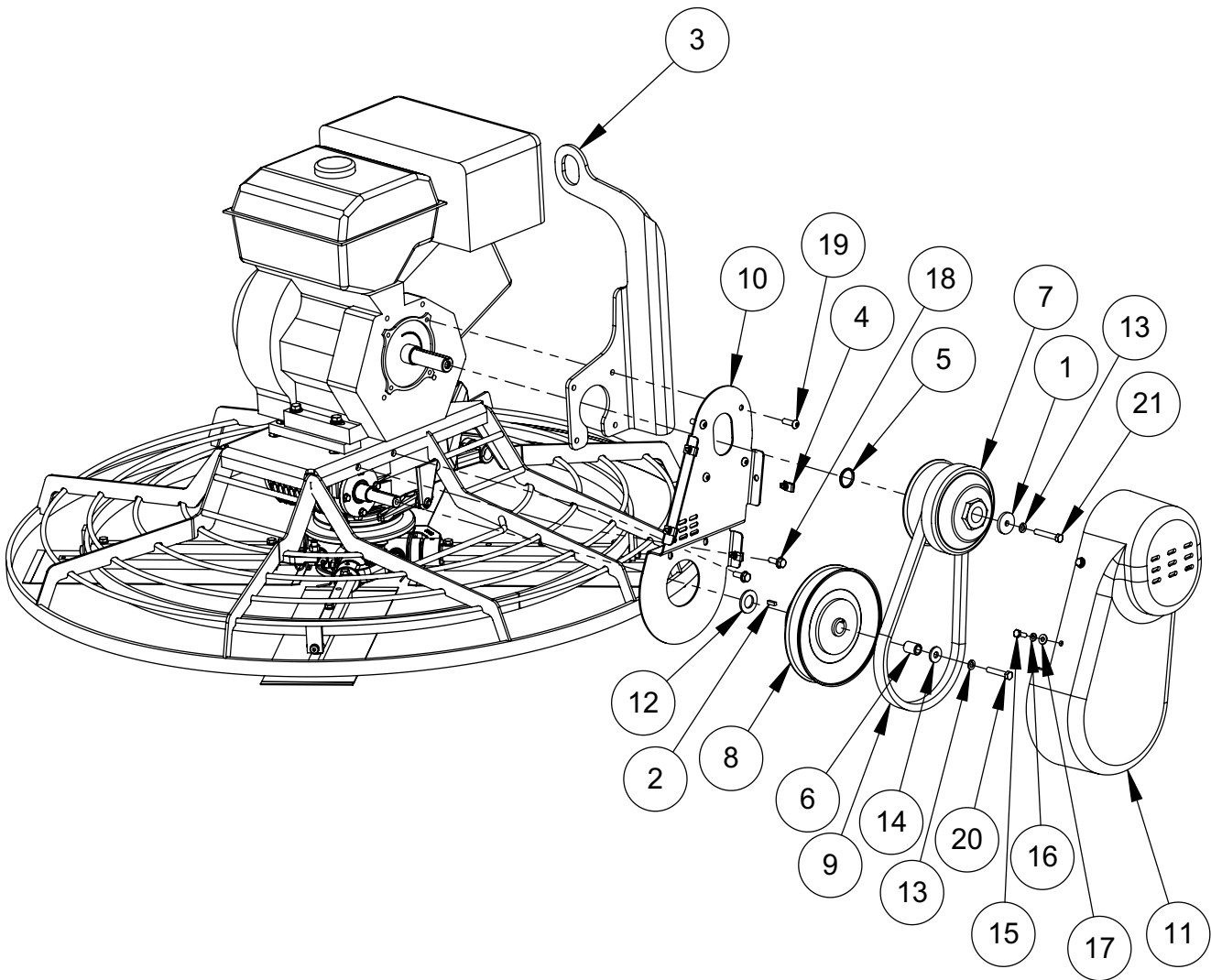

Drive Assembly

ITEM	PART NO.	DESCRIPTION	QTY.
1.	06638	WASHER, 3/8" SPECIAL	1
2.	06858	KEY, 3/16" SQUARE x 5/8" LONG	1
3.	19372	LIFT HOOK, COATED	1
4.	19804	CLIP NUT, 1/4-20	4
5.	20701	SPACER, ENGINE SHAFT	1
6.	20702	SPACER, TROWEL GEARBOX	1
7.	20704	CLUTCH, DRIVE, 40 SERIES	1
8.	20705	CLUTCH, DRIVEN, 40 SERIES	1
9.	20706	V-BELT, 40 SERIES CLUTCH, 9-3/8 CENTER	1
10.	20707	BELT GUARD, BACK PLATE	1
11.	20708	BELT GUARD, TROWEL	1
12.	22447	WASHER, 3/4 SAE, ZP	1
13.	F05LW	LOCK WASHER, 5/16, ZP	2
14.	F06SW	WASHER, 25/64, ZP	2
15.	F042006HCS	HEX HEAD SCREW, 1/4-20 x 3/4" LG. ZP	4
16.	F04LW	LOCKER, 1/4", ZP	4
17.	F04PW	WASHER, PLAIN, 1/4", ZP	4
18.	F051807FWS	FLANGE HEAD LOCK SCREW, 5/16 x 7/8" LG. ZP	2
19.	F052408BCS	BUTTON HEAD CAP SCREW, 5/16-24 x 1.0" LG.	4
20.	F051814HCS	HEX HEAD CAP SCREW, 5/16-18 x 1-3/4 GR 5, ZP	1
21.	F062418HCS	HEX HEAD CAP SCREW, 3/8-16 x 2-1/4" LG. GR 5, ZP	1
		REPLACEMENT KITS:	
	20859	KIT, CLUTCH DRIVE SPRINGS	
	Q5266721	AIR FILTER, GX270 HONDA ENGINE	

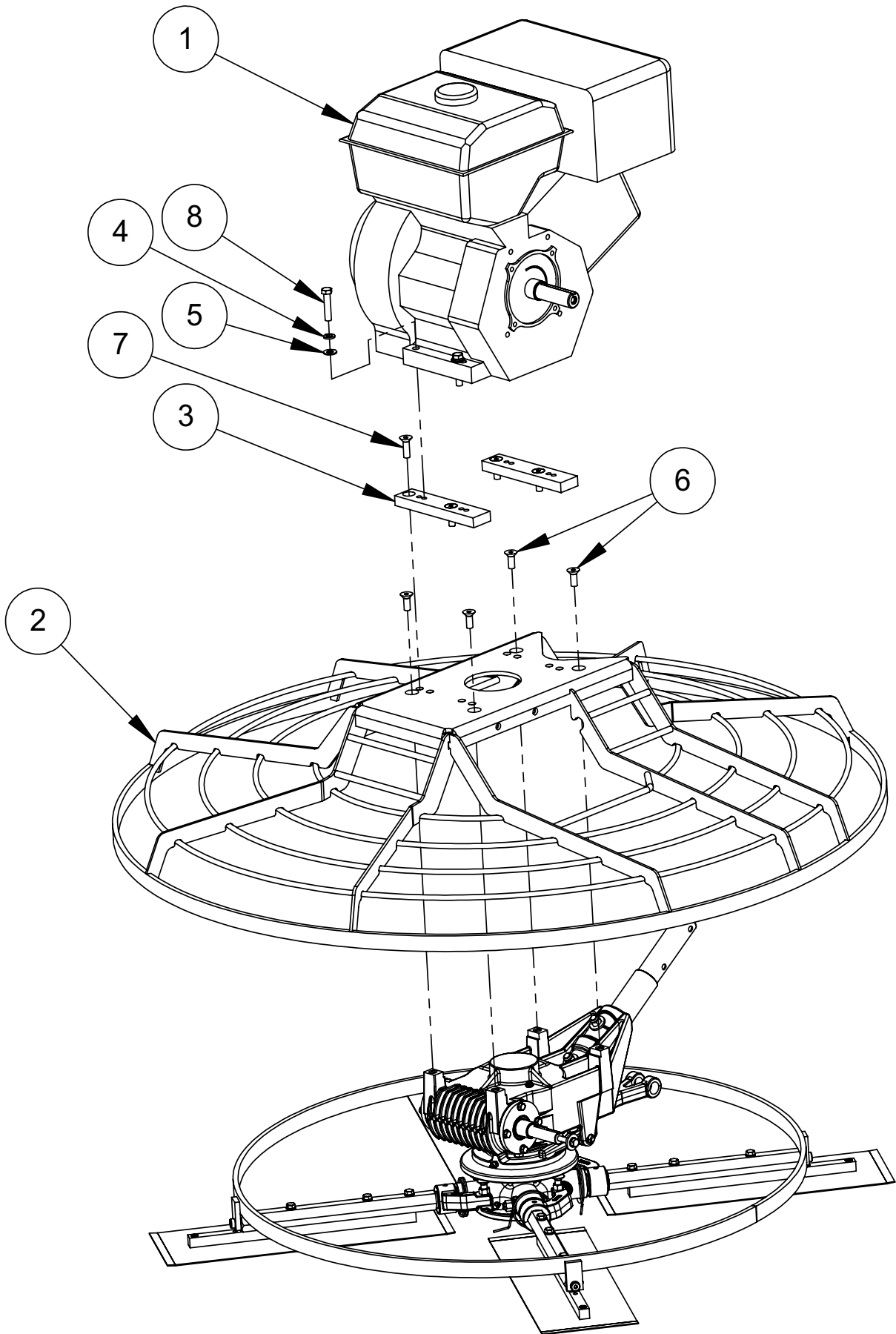

Guard Assembly

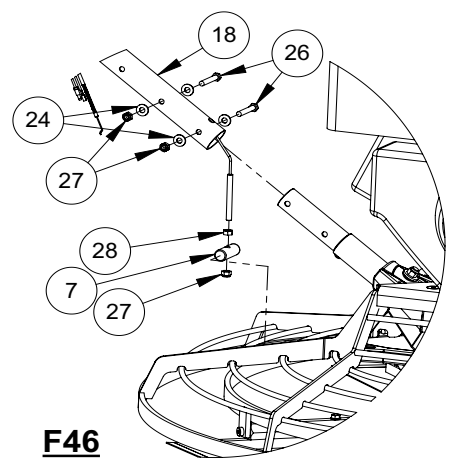
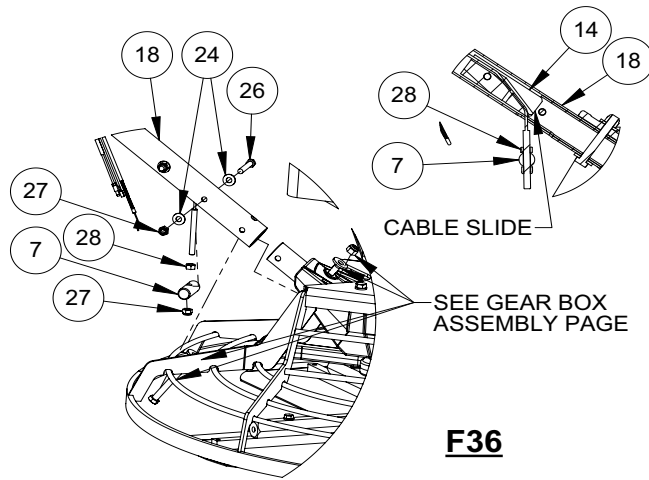
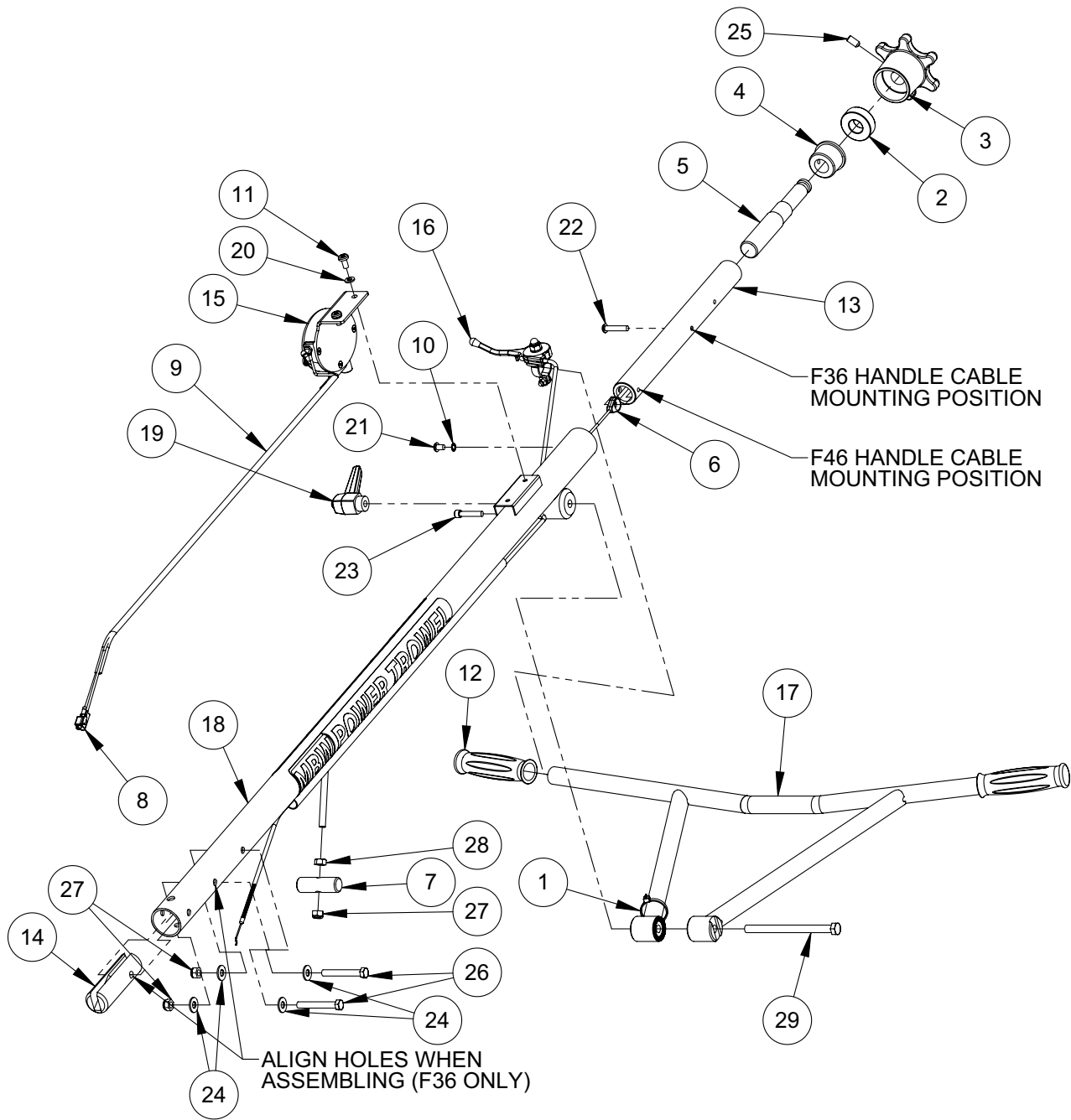

Standard Handle Assembly

ITEM	PART NO.	DESCRIPTION	F36	F46
1.	01291	CABLE TIE	1	1
2.	01302	THRUST BEARING	1	1
3.	05358	KNOB	1	1
4.	05363	BEARING	1	1
5.	05365	TILT SHAFT	1	1
6.	05381	CABLE ASSEMBLY, (Includes items #27 & #28)	1	1
7.	05395	PIVOT PIN	1	1
8.	07592	SPLICE TERMINAL	1	1
9.	07774	WIRE, SHORTING (63" long)	1	1
10.	15991	LOCK WASHER, 1/4" INTERNAL TOOTH	1	1
11.	16047	SELF TAP SCREW, 1/4-20 x 1/2	2	2
12.	21109	HANDLE GRIP	2	2
13.	21584	SHAFT, ADAPTER NUT	1	1
14.	21585	CABLE SLIDE	1	
15.	22215	SWITCH ASSEMBLY, (Includes item #9)	1	1
16.	22434	THROTTLE ASM	1	1
17.	22437	HANDLE BAR	1	1
18.	22440	HANDLE CENTER TUBE	1	1
19.	22445	HANDLE HEIGHT ADJUSTMENT LEVER, 3/8		
20.	F04LW	LOCKWASHER, 1/4	2	2
21.	F042003BCS	BUTTON HEAD SCREW, 1/4-20 x 3/8	1	1
22.	F042010BCS	BUTTON HEAD SCREW, 1/4-20 X 1-1/4 LG.	1	1
23.	F042010SCS	BUTTON HEAD SCREW, 1/4-20 X 1-1/4 LG.	1	1
24.	F05SW	WASHER, 5/16 X 3/4 X 15 GA., ZP	4	4
25.	F051805SSS	SHSS, 5/16-18 x 5/8	1	1
26.	F051818HCS	HEX HEAD SCREW, 5/16-18 X 2-1/4, GR5, ZP	2	2
27.	F0518ELN	ELASTIC LOCKNUT, 5/16-18	3	3
28.	F0518HN	HEX NUT, 5/16-18	1	1
29.	F061640HCS	HHCS, 3/8-16 x 5, GR5, ZP	1	1
		REPLACEMENT PARTS		
	22060	F36 TROWELHANDLE ASSEMBLY (includes all above except item #8 & #9)		
	22061	F46 TROWEL HANDLE ASSEMBLY (includes all above except item #8 & #9)		

"UK" HANDLE ASM.

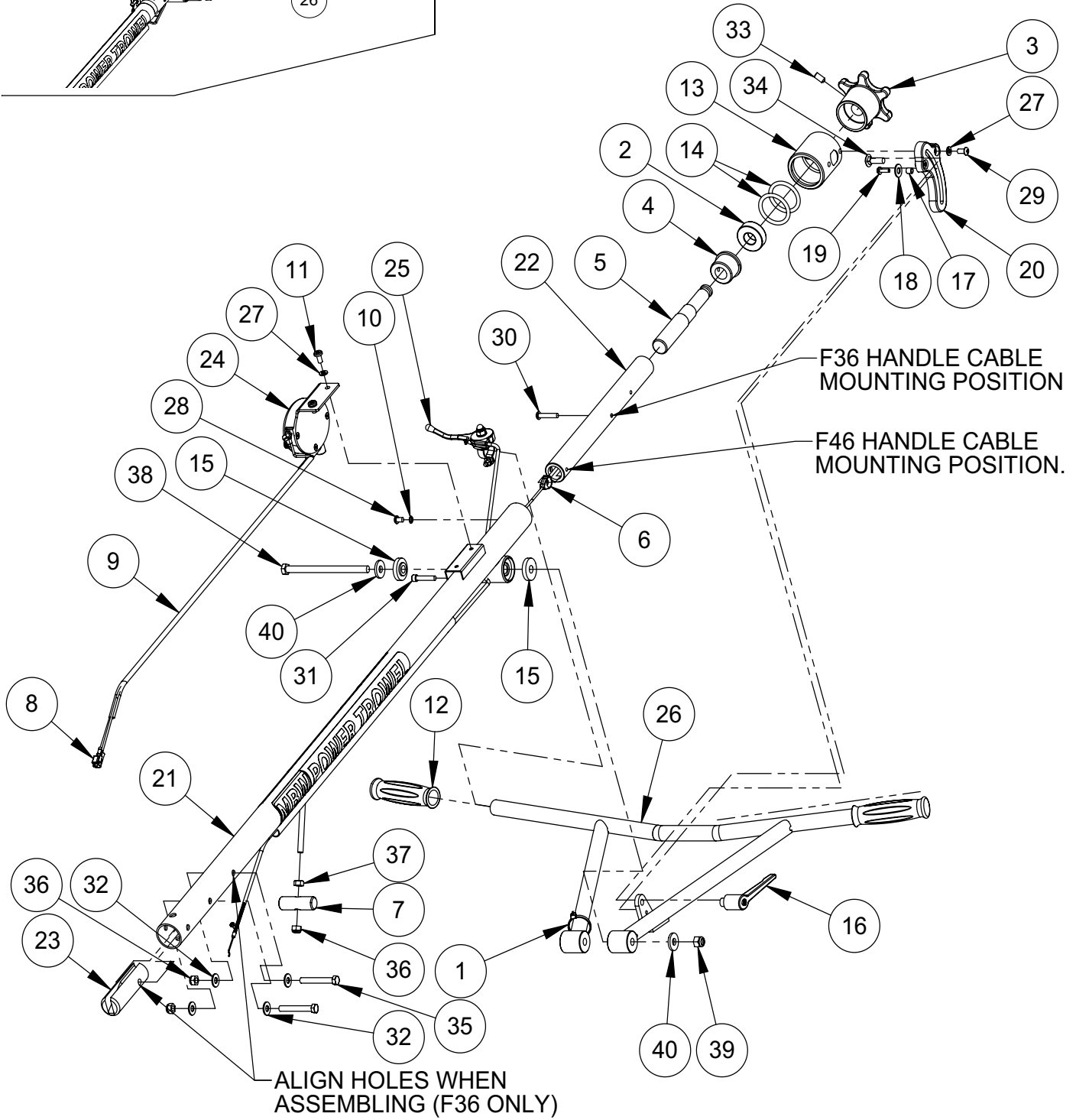
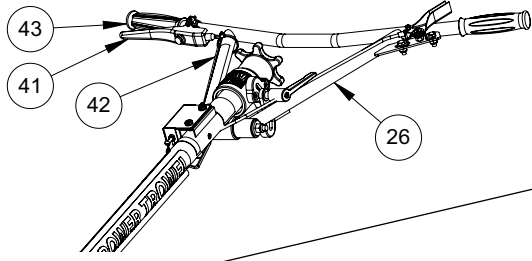

Low Vibration Handle Assembly

ITEM	PART NO.	DESCRIPTION	F36	F46
1.	01291	CABLE TIE	1	1
2.	01302	THRUST BEARING	1	1
3.	05358	KNOB	1	1
4.	05363	BEARING	1	1
5.	05365	TILT SHAFT	1	1
6.	05381	CABLE ASSEMBLY, (Includes items #36 & #37)	1	1
7.	05395	PIVOT PIN	1	1
8.	07592	SPLICE TERMINAL	1	1
9.	07774	WIRE, SHORTING (63" long)	1	1
10.	15991	LOCK WASHER, 1/4" INTERNAL TOOTH	1	1
11.	16047	SELF TAP SCREW, 1/4-20 x 1/2	2	2
12.	21109	HANDLE GRIP	2	2
13.	21176	COLLAR, LOW VIBRATION HANDLE	1	1
14.	21179	ISOLATION RING	2	2
15.	21180	ISOLATION BUSHING	2	2
16.	21181	HEIGHT ADJUSTMENT HANDLE	1	1
17.	21182	SPACER, ALUMINUM	1	1
18.	21183	WASHER, NYLON	1	1
19.	21184	HEX WASHER HEAD SCREW, #10-32 X 5/8 LG.	1	1
20.	21594	BRACKET, LOW VIBRATION HANDLE	1	1
21.	21582	HANDLE CENTER TUBE	1	1
22.	21584	SHAFT, ADAPTER NUT	1	1
23.	21585	CABLE SLIDE	1	
24.	22215	SWITCH ASSEMBLY, (Includes item #9)	1	1
25.	22434	THROTTLE ASM	1	1
26.	22455	HANDLE BAR	1	1
27.	F04LW	LOCKWASHER, 1/4	4	4
28.	F042003BCS	BUTTON HEAD SCREW, 1/4-20 x 3/8	1	1
29.	F042004BCS	BUTTON HEAD SCREW, 1/4-20 x 1/2	2	2
30.	F042010BCS	BUTTON HEAD SCREW, 1/4-20 X 1-1/4 LG.	1	1
31.	F042010SCS	BUTTON HEAD SCREW, 1/4-20 X 1-1/4 LG.	1	1
32.	F05SW	WASHER, 5/16 X 3/4 X 15 GA., ZP	4	4
33.	F051805SSS	SHSS, 5/16-18 x 5/8	1	1
34.	F051808CB	CARRIAGE BOLT, 5/16-18 X 1.0 ZP	1	1
35.	F051818HCS	HEX HEAD SCREW, 5/16-18 X 2-1/4, GR5, ZP	2	2
36.	F0518ELN	ELASTIC LOCKNUT, 5/16-18	3	3
37.	F0518HN	HEX NUT, 5/16-18	1	1
38.	F061640HCS	HHCS, 3/8-16 x 5, GR5, ZP	1	1
39.	F0616ELN	LOCKNUT, 3/8-16	1	1
40.	F06SW	WASHER, 3/8	2	2
		UK HANDLE ASSEMBLY		
41.	21071	HANDLE "DEADMAN", UK	1	1
42.	21076	WIRRE HARNESS, "DEADMAN" HANDLE, UK	1	1
43.	21110	HANDLE GRIP, "DEADMAN", UK	1	1
		REPLACEMENT PARTS		
	21580	F36 TROWELHANDLE ASSEMBLY (includes all above except item #8 & #9)		
	21581	F46 TROWEL HANDLE ASSEMBLY (includes all above except item #8 & #9)		

"UK" HANDLE ASM.

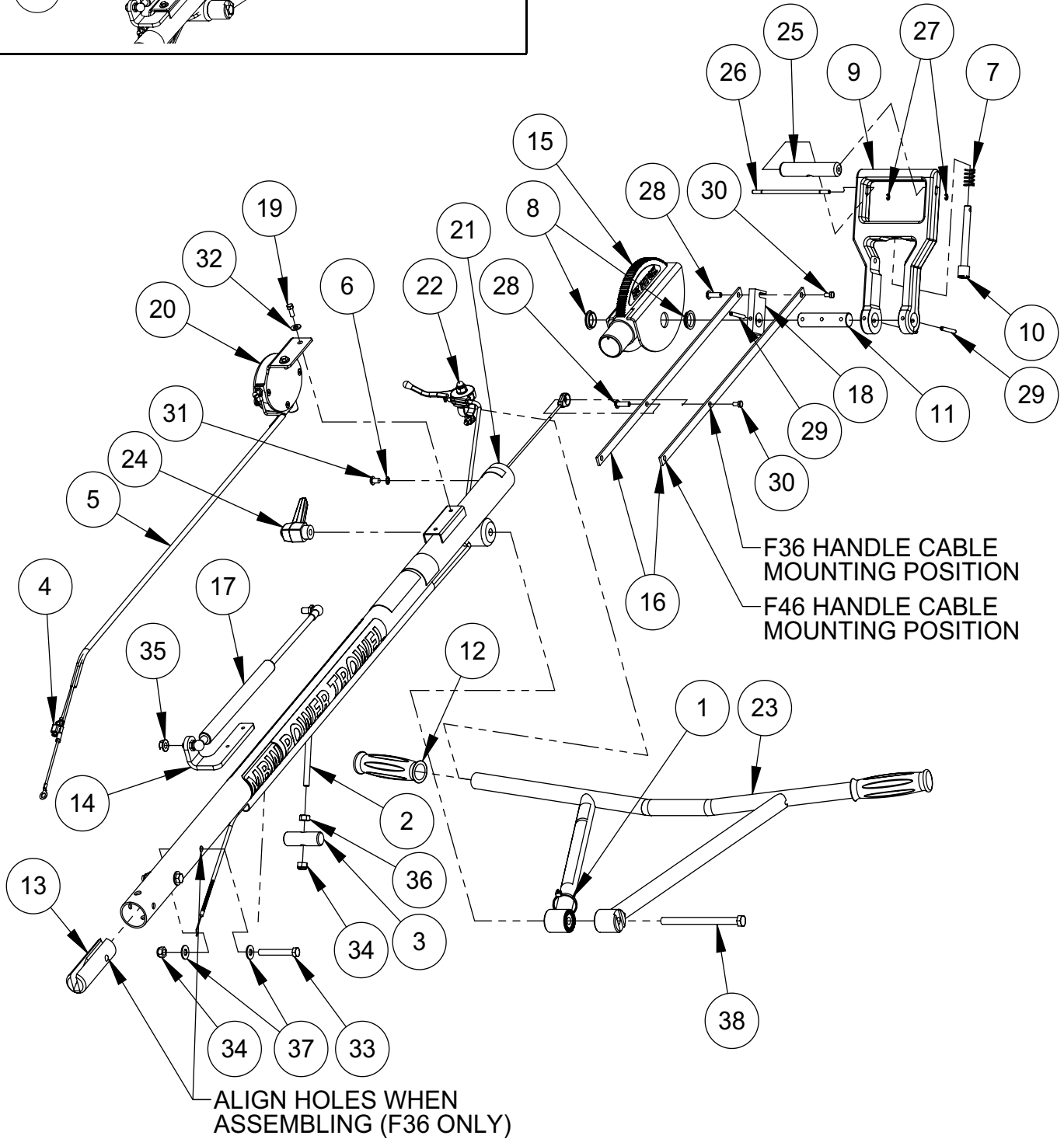
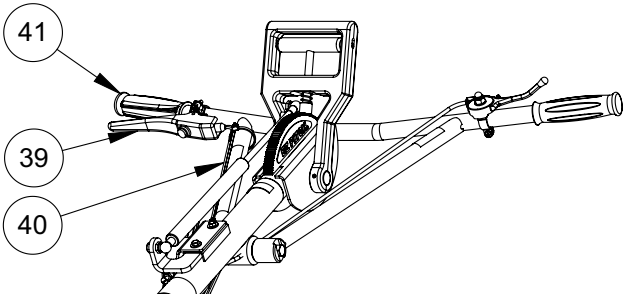

EZ Pitch Handle Assembly

ITEM	PART NO.	DESCRIPTION	F36	F46
1.	01291	CABLE TIE	1	1
2.	05381	CABLE ASSEMBLY, (Includes items #34 & #36)	1	1
3.	05395	PIVOT PIN	1	1
4.	07592	SPLICE TERMINAL	1	1
5.	07774	SHORTING WIRE ASM	1	1
6.	15991	LOCK WASHER, 1/4" INTERNAL TOOTH	1	1
7.	16040	COMPRESSING SPRING	1	1
8.	16078	CLIP BEARING	2	2
9.	16081	LEVER ARM	1	1
10.	16083	LOCK DOG	1	1
11.	16086	SHAFT, ACTIVATING	1	1
12.	21109	GRIP	2	2
13.	21585	CABLE SLIDE	1	
14.	21712	STRUT MOUNT	1	1
15.	21713	GEAR ASSEMBLY, WELDED	1	1
16.	21716	HANDLE LINK	2	2
17.	21718	GAS SPRING	1	1
18.	21724	LEVER, EZ PITCH	1	1
19.	21725	HEX HEAD SCREW SCREW, #12-34 x 1/2	2	2
20.	22215	SAFETY SWITCH ASSEMBLY (Includes item #6)	1	1
21.	22440	HANDLE CENTER TUBE	1	1
22.	22434	THROTTLE ASM	1	1
23.	22437	HANDLE BAR	1	1
24.	22445	HANDLE HEIGHT ADJUSTMENT LEVER, 3/8-16	1	1
25.	22585	TRIGGER PULL	1	1
26.	22586	DOWEL PIN, 3/16 x 5	1	1
27.	22587	RETAINING RING, E-STYLE, 3/16	2	2
28.	22794	SCREW, BINDING, 1/4 3/4 LG.	2	2
29.	F0312RP	ROLL PIN, 3/16 x 1-1/2	3	3
30.	F032403HCS	HEX HEAD SCREW, #10-24 X 3/8 LG.	2	2
31.	F042003BCS	BUTTON HEAD SCREW, 1/4-20 x 3/8 ZP	1	1
32.	F04SW	WASHER, 1/4	2	2
33.	F051818HCS	HEX HEAD SCREW. 5/16-18 X 2-1/4 GR 5 ZP	2	2
34.	F0518ELN	NYLOC LOCKNUT, 5/16-18	3	3
35.	F0518FN	FLANGE LOCK NUT, 5/16-18	1	1
36.	F0518HN	HEX NUT, 5/16-18	1	1
37.	F05SW	WASHER, 5/16	4	4
38.	F061640HCS	HHCS, 3/8-16 x 5, GR5, ZP	1	1
		UK HANDLE ASSEMBLY:		
39.	21071	HANDLE "DEADMAN", UK	1	1
40.	21076	WIRRE HARNESS, "DEADMAN" HANDLE, UK	1	1
41.	21110	HANDLE GRIP, "DEADMAN", UK	1	1
		REPLACEMENT PARTS:		
	16080	LEVER ARM ASSEMBLY (includes items 7, 9, 10, 25, 26 & 27)		
	21721	F36 TROWELHANDLE ASSEMBLY (includes all above except item #4)		
	21720	F46 TROWEL HANDLE ASSEMBLY (includes all above except item #4)		

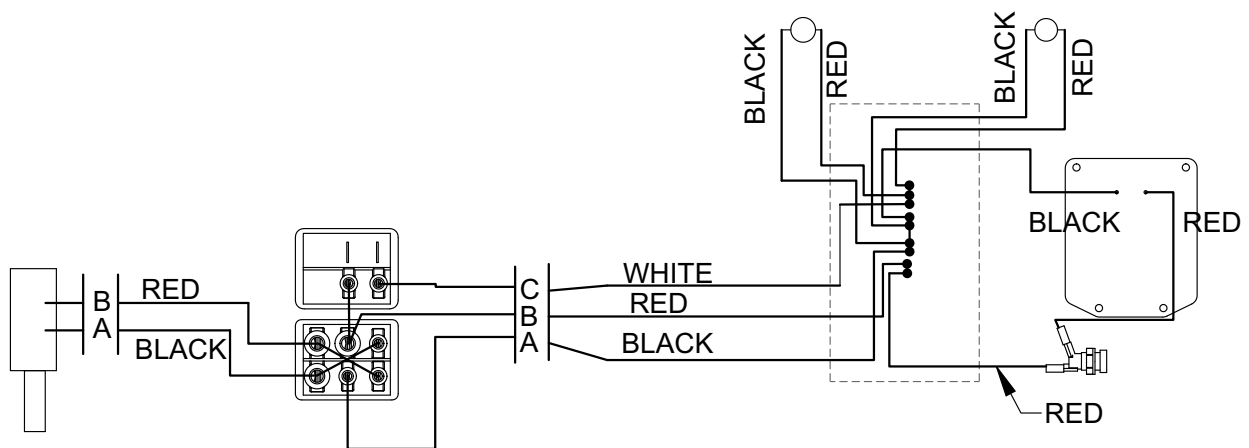
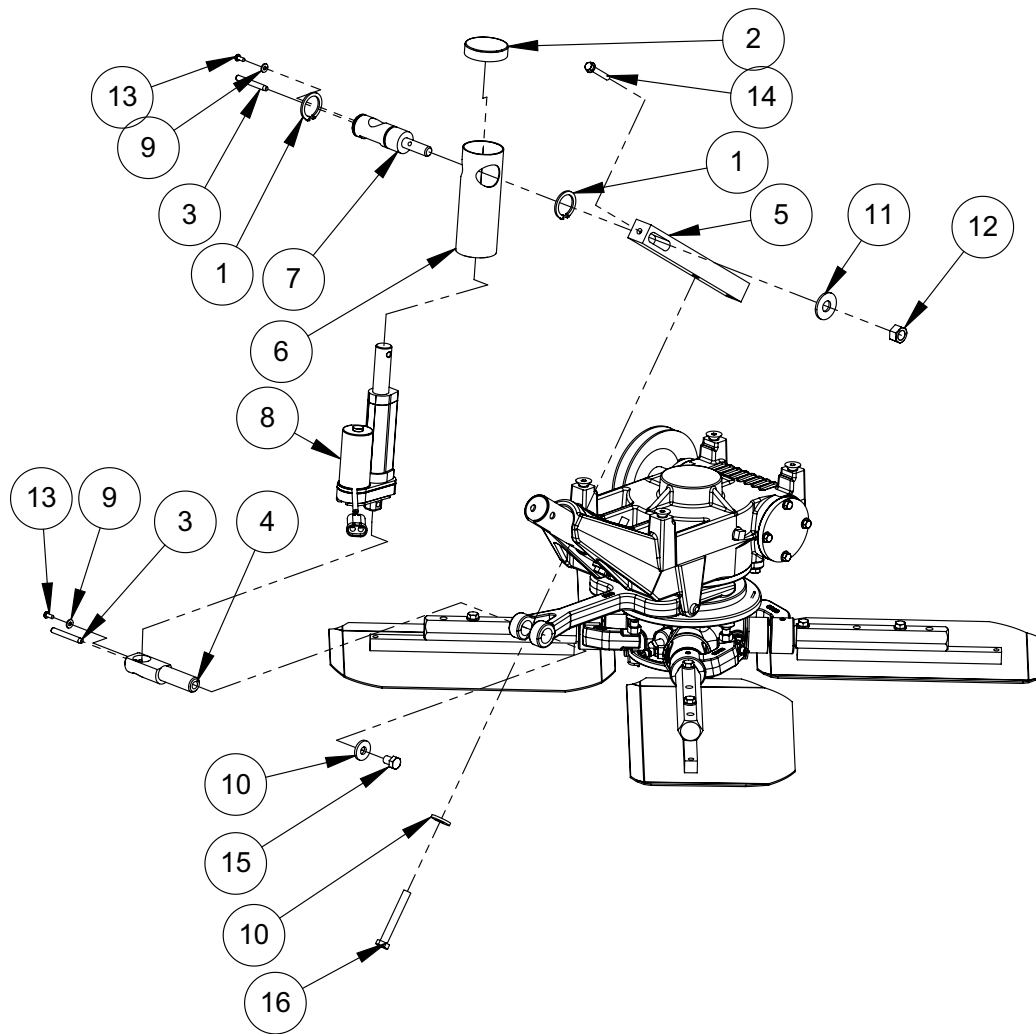

Power Pitch Actuator & Wiring

ITEM	PART NO.	DESCRIPTION	QTY
1.	01244	RETAINING RING, EXT	2
2.	22690	PUSH ON CAP, 2.0"	1
3.	22691	PULL OUT DOWEL PIN, 1/4	2
4.	22692	ACTUATOR MOUNT, BOTTOM	1
5.	22693	ACTUATOR SUPPORT BRACKET	1
6.	22694	SHIELD, ACTUATOR	1
7.	22698	ACTUATOR MOUNT, TOP	1
8.	22719	ACTUATOR ASM	1
9.	F02SW	WASHER, 3/16 X 7/16 X 18GA	2
10.	F06SW	WASHER, 9/16 X 1-3/8 X 12GA	1
11.	F08SW	WASHER, 9/16 X 1-3/8 X 12GA	1
12.	F0813HN	NUT, HEX 1/2-13 ZP	1
13.	F023203PMS	PHMS, #8-32 X 3/8 ZP	2
14.	F042012FWS	FWLS, 1/4-20 X 1-1/2 ZP	1
15.	F061604HCS	HHCS, 3/8-16 X 1/2 GR5 ZP	1
16.	F061622HCS	HHCS, 3/8-16 X 2-3/4 GR5 ZP	2

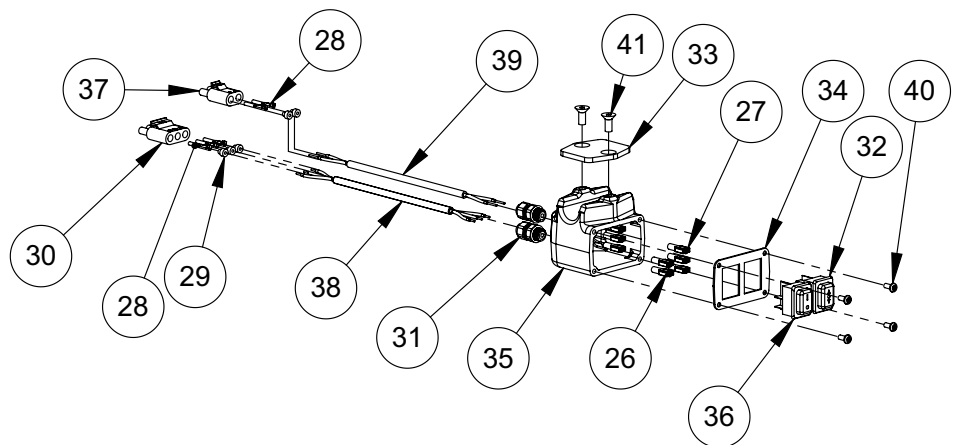
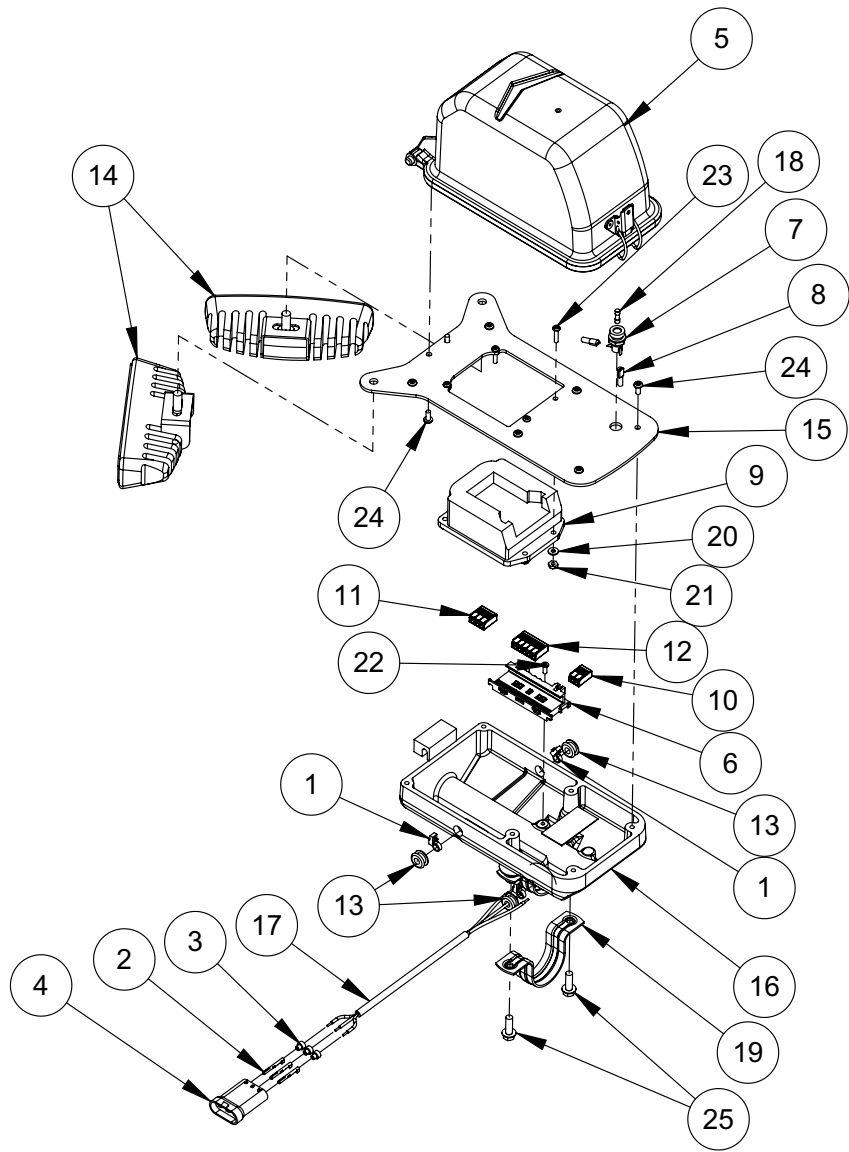

Power Pitch Switch & Battery

ITEM	PART NO.	DESCRIPTION	QTY
1.	01291	CABLE TIE	3
2.	12303	TERMINAL PIN	3
3.	12304	SEAL, CONNECTOR WIRE	3
4.	12306	CONNECTOR SHROUD	1
5.	22594	M18 COVER ASM	1
6.	22596	MOUNT, WIRE JUNCTION	1
7.	22640	FUSE HOLDER	1
8.	22641	QUICK CONNECT, .110	2
9.	22665	SOCKET, TWO WIRE	1
10.	22684	SPLICE, CLAMP ON, TWO WIRE	1
11.	22685	SPLICE, CLAMP ON, THREE WIRE	1
12.	22686	SPLICE, CLAMP ON, FIVE WIRE	1
13.	22688	GROMMET	3
14.	22699	LED LIGHT	2
15.	22700	PLATE, BATTERY MOUNT	1
16.	22703	BATTER MOUNT, MACHINED	1
17.	22721	CORD, BULK, 3 CON, BLACK	12"
18.	22723	FUSE, 4A, 2AG	1
19.	22779	CLAMP, PAINTED	1
20.	F01PW	WASHER, 5/32 X 3/8 X 18GA	4
21.	F0132HN	NUT, HEX #6-32 ZP	4
22.	F013203BCS	BCS, #6-32 X 3/8	1
23.	F013205PMS	PMS, #6-32 X .625	4
24.	F023203PMS	PHMS, #8-32 X 3/8 ZP	8
25.	F042006FWS	FWLS, 1/4-20 X 3/4	2
26.	11444	TERMINAL, FEMALE DISCONNECT	5
27.	11618	TERMINAL, FEMALE DISCONNECT	3
28.	12302	TERMINAL, SLEEVE	5
29.	12304	SEAL, CONNECTOR WIRE	5
30.	12307	CONNECTOR TOWER	1
31.	22110	CORD GRIP	2
32.	22695	SWITCH, DPDT	1
33.	22696	CLAMPING PLATE	1
34.	22697	SWITCH PLATE	1
35.	22701	SWITCH MOUNT, MACHINED	1
36.	22706	SWTICH, ON-OFF	1
37.	22708	CONNECTOR, TOWER, TWO WIRE	1
38.	22721	CORD, BULK, 3 CON, 18 GA, BLACK	18"
39.	22722	CORD, BULK, 2 CON, 18 GA, BLACK	54"
40.	F023203PMS	PHMS, #8-32 X 3/8 ZP	4
41.	F042005FSS	FSS, 1/4-20 X 5/8	2
	22717	BATTERY ASM, POWER PITCH (INCLUDES 1-18, 20-24)	
	22707	SWITCH ASM (INCLUDES 26-32, 34-38, 39-40)	

WARRANTY

1. IN GENERAL - The warranties described in this document are provided by M-B-W, INC. and MBW EUROPE, LTD. ("MBW") to define what is, what is not, and for how long machines and parts are covered against material defects and/or defective workmanship. To obtain warranty service, the purchaser must, within the Warranty Period (defined in Paragraph 3): (i) report the product defect to an authorized repair center, (ii) make a written request for repair, (iii) provide proof of purchase to the authorized repair center, and (iv) deliver the equipment to the authorized repair center. A list of authorized repair centers is available on the MBW website (mbw.com) or by contacting MBW at 800-678-5237.

2. COVERED - MBW's obligation under this limited warranty is limited to the cost of the parts and the labor to repair any defect in material and/or workmanship at an authorized MBW repair center. Transportation charges are not covered by this limited warranty.

3. WARRANTY PERIODS - The Warranty Period begins on, as applicable: (i) the product purchase date by an end user or (ii) the first day the product is put into rental or two years after invoice date from MBW to Dealer, whichever starts the warranty period first. To insure that your warranty is in place, fill out the warranty card and mail it in or register your product online at www.mbw.com/service-support/warranty-registration. The warranty is nontransferable.

The Warranty Period ends after:

- A. New Ground compaction equipment - 2 years.
 - B. New Concrete finishing equipment - 1 year.
 - C. New Utility equipment - 1 year.
 - D. Demonstration equipment - 6 months.
 - E. Wear parts: lubricants, filters, belts and shock mounts - 30 days.
4. NOT COVERED- This warranty does not include, and MBW specifically excluded from any warranty:
- A. Used equipment - all used equipment is not warranted and is sold 'as is' 'where is' with all defects.
 - B. Replacement electrical parts, including but not limited to: electric motors, circuit boards, switches, are not warranted or returnable.
 - C. OEM: engines, batteries, and chargers. Those warranties are covered by the manufacturer.
 - D. Consumable parts: trowel and screed blades.
 - E. Equipment that has been: altered, abused, neglected, not maintained, or modified to run outside its specifications. Any modification to the machine or its parts makes this warranty null and void.
 - F. Other: damage to a product from normal wear, air freight, overtime, pickup and delivery, temporary replacement rentals, freight damage, or other similar incidents.
 - G. Product used in a fashion it was not designed for.
 - H. Parts and labor not performed by authorized dealers.

It is at MBW's discretion if warranty applies and has the right to adjust labor rates on a claim by claim basis.

5. OTHER - IT IS EXPRESSLY AGREED THAT THIS SHALL BE THE SOLE AND EXCLUSIVE REMEDY UNDER THIS WARRANTY. UNDER NO CIRCUMSTANCES SHALL MBW BE LIABLE FOR ANY COSTS, LOSS, EXPENSE, DAMAGE, SPECIAL DAMAGES, DIRECT DAMAGES, INCIDENTAL DAMAGES, EXEMPLARY, CONSEQUENTIAL, OR PUNITIVE DAMAGES ARISING DIRECTLY OR INDIRECTLY FROM THE USE OF MBW PRODUCT OR DAMAGES FOR LOSS OF USE, LOSS OF ANTICIPATED PROFITS, INCOME, OR ECONOMIC LOSSES OF ANY KIND. MBW'S LIABILITY TO BUYER UNDER THESE WARRANTIES FOR THE PRODUCT IS LIMITED AS SET FORTH HEREIN, WHETHER BASED UPON WARRANTY, CONTRACT, NEGLIGENCE, TORT, STRICT LIABILITY OR ANY OTHER THEORY OF LIABILITY, INCLUDING BUT NOT LIMITED TO FRAUD, MISREPRESENTATION, BREACH OF CONTRACT, PERSONAL INJURY, PRODUCTS LIABILITY OR ANY OTHER THEORY.

MBW'S LIABILITY UNDER ANY WARRANTY HEREUNDER, WHETHER EXPRESS OR IMPLIED, SHALL NOT EXCEED THE COST OF REPAIR OR REPLACEMENT OF DEFECTIVE PARTS OF THE PRODUCT OR THE PRODUCT. BUYER MAY NOT BRING ANY ACTION UNDER THESE WARRANTIES MORE THAN ONE YEAR AFTER THE CAUSE OF ACTION HAS ACCRUED.

THE FORGOING WARRANTY IS EXPRESSED IN LIEU OF ALL OTHER WARRANTIES, EXPRESSED OR IMPLIED, INCLUDING THE WARRANTIES OF MERCHANTABILITY, FITNESS FOR USE, AND FITNESS FOR A PARTICULAR PURPOSE, AND ALL OTHER OBLIGATIONS OR LIABILITY ON MBW'S PART. MBW SPECIFICALLY DISCLAIMS AND EXCLUDES ANY AND ALL WARRANTIES OF MERCHANTABILITY AND FITNESS FOR A PARTICULAR PURPOSE.

MBW NEITHER ASSUMES NOR AUTHORIZES ANY OTHER PERSON TO ASSUME ON BEHALF OF MBW ANY OTHER LIABILITY OR WARRANTY IN CONNECTION WITH THE SALE OR SERVICE OF ANY MBW PRODUCT.

Some states do not allow limitations on how long an implied warranty lasts, so the above limitation may not apply to you. This warranty gives you specific legal rights, and you may also have other rights which vary from state to state.